

MAGTROL

Model 5240

*Programmable
Dynamometer Controller*

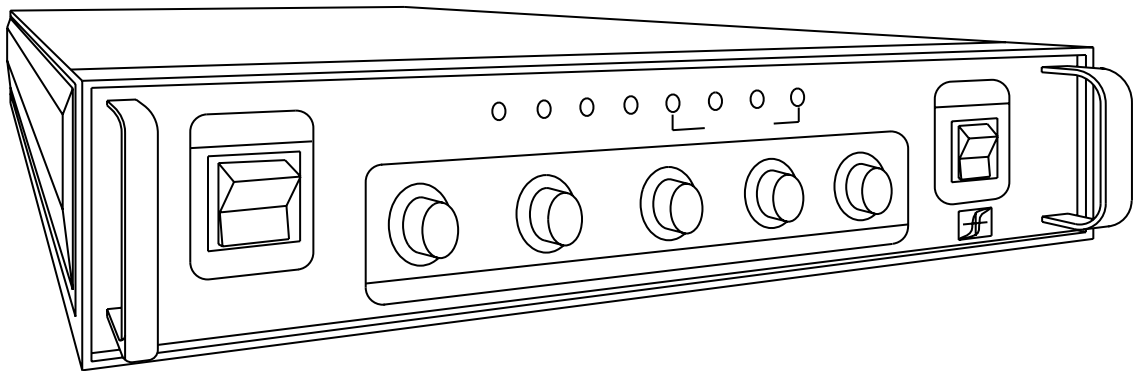

User's Manual

MAGTROL, INC.
Sales and Technical Assistance

70 Gardenville Parkway
Buffalo, New York 14224

In New York - (716) 668-5555
Outside N.Y. - (800) 828-7844
Fax - (716) 668-8705

www.magtrol.com

Manufacturers of:
Motor Test Equipment
◆
Hysteresis Brakes and Clutches

While every precaution has been exercised in the compilation of this document, Magtrol, Inc., assumes no responsibility for errors or omissions. Additionally, no liability is assumed for any damages that may result from the use of the information contained within this publication.

IBM® is a registered trademark of International Business Machines Corporation.

Quick Basic® is a registered trademark of Microsoft Corporation.

Microsoft® is a registered trademark of Microsoft Corporation.

Table of Contents

SALES AND TECHNICAL ASSISTANCE	ii
1 - INTRODUCTION	1
LINE VOLTAGE	1
INITIAL CHECKOUT	1
OPERATIONAL/EQUIPMENT CHECK	2
MODEL 5240 CAPABILITIES	3
2 - INSTALLATION	4
GPIB-COMPUTER INSTALLATION	4
SOFTWARE INSTALLATION	4
PRIMARY ADDRESS	5
DATA ACQUISITION	5
DATA ACQUISITION PROBLEMS	6
3 - INSTRUCTION SET	7
DYNAMOMETER CONTROL MODES	7
SPEED CONTROL RANGING	7
MODEL 5240 INSTRUCTION SET	8
FRONT PANEL CONTROL FUNCTIONS	12
<i>Torque</i>	12
<i>Speed</i>	12
<i>Current Gain</i>	12
<i>Proportional Gain</i>	12
4 - CONTROLS, LEDES AND I/O	12
<i>Error</i>	13
<i>Stability</i>	13
FRONT PANEL INDICATORS (LEDS)	13
<i>Dyno Brake</i>	13
<i>GPIB Error</i>	13
<i>GPIB Transfer</i>	13
<i>Speed Sync</i>	13
<i>Auto Speed Range</i>	14
<i>GPIB Torque</i>	14
<i>GPIB Speed</i>	14
<i>CTLS Active</i>	14
MODEL 5240 ELECTRICAL I/O	14
<i>GPIB Interface</i>	14
DYNAMOMETER BRAKE	15
ACCESSORY TORQUE-SPEED OUTPUT	15
ACCESSORY CABLE	16
DYNAMOMETER	16
OPERATING INSTRUCTIONS	17
<i>Manual Torque Control</i>	17
<i>GPIB Torque Control (Computer Control)</i>	18
<i>Manual Control</i>	18
<i>GPIB Speed Control (Computer Control)</i>	19
5 - CALIBRATION	21
BEFORE PROCEEDING	21
TRIMPOT FUNCTION	22
TORQUE ZERO (NULL) ADJUSTMENT	22
FULL SCALE TORQUE CALIBRATION	22
ACCESSORY TORQUE OUTPUT CALIBRATION	23

MANUAL TORQUE CONTROL ZERO	23
GPIB "Q" COMMAND TORQUE NULL	23
MODEL 5240 SPECIFICATIONS	24
<i>Speed Control</i>	24
<i>Torque Control</i>	24
A WORD ON SPEED VARIATIONS	24
6 - CIRCUIT DESCRIPTION	25
TACHOMETER	25
SPEED CONTROL	26
<i>GPIB Speed Control</i>	26
MANUAL SPEED CONTROL	27
TORQUE CONTROL	27
<i>GPIB Torque Control</i>	27
MANUAL TORQUE CONTROL	27
SALIENT POLE "COGGING"	28
I/O AND MAIN DATA PROCESSING	28
APPENDIX A: PROGRAMMING EXAMPLES	29
SPEED-TORQUE CRT DISPLAY	29
RECALL MODEL 5240 DATA FROM MEMORY	30
PROGRAMMING EXAMPLE FOR "I" COMMAND USE	30
PROGRAMMING EXAMPLE FOR "Z" COMMAND USE	31
APPENDIX B: INERTIA CORRECTION	32
INERTIAL EFFECT ON MOTOR TEST DATA	32
DATA TIMING FACTOR	32
PROCEDURE	32
INERTIA CANCELLATION PROGRAM	33
<i>Programming steps</i>	34
CORRECTING TEST RUN PERFORMANCE DATA	35
APPENDIX C: DRAWINGS	36
78B155	36
78B156	37
78B157	38
78B159	39
MAGTROL LIMITED WARRANTY	40

<p>While every precaution has been exercised in the compilation of this document, Magtrol Incorporated assumes no responsibility for errors or omissions. Additionally, no liability is assumed for any damages that may result from the use of the information contained in this publication.</p>
--

1 - Introduction

Your Model 5240 has been adequately packaged for shipping. Please save all shipping cartons and packaging material until the unit has been thoroughly checked. If there is evidence of shipping damage, notify your carrier and Magtrol Customer Service as soon as possible.

Be sure to check the carton and packaging material carefully for cord sets and other hardware.

LINE VOLTAGE

WARNING! Please check the line voltage setting before operation!

Model 5240 will operate from either a 120V/60Hz or 240V/50Hz power source, but the unit must be set for the appropriate point-of-destination line power. This adjustment is made using a switch within the *line cord receptacle* on the rear panel.

The line cord is a detachable NEMA Standard 3 wire. All Magtrol Dynamometers and Electronic Products require that cabinets and fixtures be earth grounded for proper equipment operation and to ensure safety of operating personnel.

INITIAL CHECKOUT

NOTE: Throughout this manual, the following terms are used:

- LED refers to the Light Emitting Diode indicators on the front panel of Model 5240.
- The term GPIB (General Purpose Interface Bus) is interchangeable with IEEE-488.
- “Q” refers to Torque.
- “N” refers to Speed.
- CW means Clockwise
- CCW means Counterclockwise

In order to perform the following operational check, you must have a Magtrol Dynamometer with a test motor installed. No computer interface or digital torque-speed readout equipment is necessary. Two cables are required to connect Model 5240 to the dynamometer:

- 14 pin Instrumentation Ribbon Connector Cable.
- 2 pin Dynamometer Brake Power Cable.

Your Dynamometer User’s Manual, Chapter 1, shows how these cables are connected.

OPERATIONAL/EQUIPMENT CHECK

1. Set the Dynamometer BRAKE switch (left side) ON.
Set the TORQUE potentiometer fully CCW (zero load torque).
Set the SPEED potentiometer fully CW (max. range).
Set the GAIN, ERROR and STABILITY controls to approximately the 9 o'clock position.
2. Turn ON the Model 5240 POWER switch. The green CTLS ACTIVE LED should illuminate. Model 5240 is now in the manual TORQUE control mode. **NOTE:** At power on, Model 5240 defaults to the manual TORQUE control mode.
3. Start the test motor and allow the motor speed to stabilize for a few seconds at its no load speed.
4. Slowly rotate the TORQUE control knob clockwise (CW - in direction of arrow). **NOTE:** The arrow direction indicates that the applied torque increases in the CW direction.

The DYNO BRAKE LED will illuminate as brake power is applied, causing load torque to be applied to the motor. The applied torque increases as the knob is rotated CW. For most motors, torque loading will be observed by a reduction of motor speed as torque is applied. Be careful not to overload or stall the motor, as prolonged overload can cause the motor to overheat.

5. Return the TORQUE control to the fully CCW position. The DYNO BRAKE LED should go out as the motor load torque returns to zero.
6. Switch the BRAKE ON/OFF rocker switch OFF and then ON. The AUTO RANGE LED will illuminate, indicating that the Model 5240 is now in the manual speed control mode. The CTLS ACTIVE and AUTO RANGE LEDs should be illuminated.
7. Slowly rotate the SPEED control knob counterclockwise (CCW - opposite the arrow direction). The arrow direction indicates that motor speed control increases with CW rotation and decreases with CCW rotation. The DYNO BRAKE LED should illuminate, and the motor should slow down under speed control.

NOTE: If the motor is unstable, adjust the STABILITY control CW as necessary to restore stability. Be careful not to overload or stall the motor, as prolonged overload can cause the motor to overheat.

Return the SPEED control knob fully CW.

8. Remove power to the motor under test.

This completes the Model 5240 manual mode operational checks. For GPIB PC computer control mode use, please refer to section 2 - GPIB COMPUTER INSTALLATION.

MODEL 5240 CAPABILITIES

The Model 5240 is a speed controlled power supply, designed to interface with any type of IBM compatible computer using an IEEE-488 instrument controller. Model 5240 may be used to control any Magtrol Load Cell Dynamometer. In addition, it may be set to return current Torque-Speed data to the computer. The unit may be used without a computer, but will function at only a fraction of its capability and will require a Magtrol digital readout device to display torque and speed.

In a computer controlled environment, the following motor testing capabilities are available:

- Proportional (P), plus Integral (I), plus Derivative (D) closed loop speed control - PID loop. Control parameters are adjustable by the front panel controls of proportional GAIN (P), ERROR (I) and STABILITY (D).
- Torque (Q) vs. Speed (N) data acquisition, at a rate of 10 readings per second.
- Automatic Q-N continuous (progressive) loading in either decreasing or increasing speed mode.
- Capability to remove the Effects of Inertia from dynamically-obtained data. See Appendix B.
- Q or N programmable test points.
- Data storage (nonvolatile) within the unit, up to 500 Q-N test points.
- Complete curve capability for most types of motors, including single/poly phase induction, AC/DC series, PMDC, brushless DC, air and internal combustion (if suitably coupled).

NOTE: In speed mode, closed loop control between locked rotor and 60 RPM may be erratic, depending on the test motor. Programmed loading *in the speed mode* may therefore not be possible for very low speed gear-head and stepper motors.

2 - Installation

Please be sure that the computer and Model 5240 are both turned **OFF** when you install the GPIB connector cable.

If you have completed the equipment checkout as outlined in Chapter 1, the Model 5240-Dynamometer interconnection is complete. If an optional Magtrol Digital Readout is to be interfaced with the unit, you will need a Magtrol 7 pin DIN to 14 pin Ribbon Connector Cable. This cable assembly is Magtrol PN 88CS09 and is in stock at the factory. If a readout was supplied with Model 5240, the cable will be included. Please refer to Page 1-2 of your Dynamometer User's Manual for instructions on connecting the readout.

Although numerous computer interfacing methods exist, all Magtrol electronic instruments use the IEEE-488 (GPIB) Standard for the following reasons:

- GPIB parallel communication is inherently faster than serial interfaces.
- In motor testing, at least five separate parameters must be *synchronized*. A system of easy, fast access to more than one instrument is essential. With the GPIB, up to 15 instruments may be accessed on one port.
- The GPIB has rigid data formatting and hardware standards. This increases the chances that all functions will work properly when the hardware/software is installed.

GPIB-COMPUTER INSTALLATION

The GPIB interface is not a standard item on most computers. An interface card must be installed, and the driver software made resident on disk. Several manufacturers provide these products, and some systems exchange data more rapidly than others. In motor testing, the test rate and speed of data acquisition is very important. We recommend using National Instruments Corporation's PN GPIB-PC2A for IBM® compatible PCs. Additionally, you will need to install an IEEE-488 Cable between the computer and Model 5240.

SOFTWARE INSTALLATION

A number of formatting questions must be answered during GPIB software installation. The following items pertain to Model 5240:

All GPIB data acquisition systems require the use of data termination characters. Model 5240 uses the Hewlett Packard HPIB standard termination characters "Carriage Return (CR)-Line Feed (LF)" (in that order), and looks for these symbols to terminate communication.

Codes for CR - LF			
	BASIC	HEX	DEC
CR =	CHR\$(13)	0D	13
LF =	CHR\$(10)	0A	10

You may be asked to set a communication fault delay timeout, to alleviate a computer hang-up. Do not set this period too short. Leave at least one second. If the computer resets the interface prematurely, the host instrument may hang up, waiting to find the never-to-happen "CR-LF."

PRIMARY ADDRESS

All instruments serviced on the GPIB have a separate primary address code. On the rear panel, next to the GPIB connector, there is an opening which provides access to the code selection switch. The default setting (from the factory) on Model 5240 is nine (09). If you wish to change the code, this chart will help you obtain the setting you want. Please note that the MSB is to the right. Switch segment identification resulted in the binary code notation being reversed from the standard convention, where the LSB is normally on the right.

Some PC interfaces will access 1 to 15 (4 Bit) primary address numbers only. Others may access up to 31 (5 Bit) codes, even though the GPIB capability is limited to 15 instruments. The Model 5240 Primary Address uses the 5 bit format. Before selecting a value greater than 15, however, check with your particular interface's primary address code range capability.

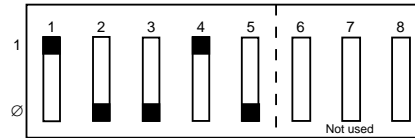

CODE SWITCH					
Segment #					Code
1	2	3	4	5	
0	0	0	0	0	0
1	0	0	0	0	1
0	1	0	0	0	2
1	1	0	0	0	3
0	0	1	0	0	4
1	0	1	0	0	5
0	1	1	0	0	6
1	1	1	0	0	7
0	0	0	1	0	8
1	0	0	1	0	9
0	1	0	1	0	10
1	1	0	1	0	11
0	0	1	1	0	12
1	0	1	1	0	13
0	1	1	1	0	14
1	1	1	1	0	15
0	0	0	0	1	16

DATA ACQUISITION

When the systems are interconnected, the first thing you might want to verify is that Model 5240 and the host computer are communicating.

Model 5240 requires no specific *input* instruction in order to *output* immediate torque and speed data. Simply follow your computer/GPIB interface instructions and issue a data input or read command. If our primary address is set and addressed correctly, Model 5240 will respond. It will probably be necessary to set your input variable to 15, *i.e.* 13 characters plus CR-LF.

Speed-Torque data is a fixed length string, ASCII format, floating point decimal, structured as follows:

SddddTddd.L

Where d = decimal digit, 0 through 9, "S" indicates that the following 5 digits are RPM, and "T" indicates that the next 4 digits + decimal point is Torque. The last character (shown as "L") may be either "L" or "R." "L" = CCW dynamometer *torque* application, "R" = CW.

The decimal point location will depend on the specific dynamometer and torque range in use. The CR-LF are symbolic and will not display.

For example: Suppose a motor is running at 1725 RPM clockwise, with the dynamometer loading the motor to 22.6 oz.in. Model 5240 will transmit:

S01725T022.6R

or

S01725T22.60R

By string manipulation, the speed-torque and shaft direction (if required) may be extracted and assigned separate numerical variables for data processing. No decimal point is used in the speed value. The torque always contains a decimal point.

The following is a simple - single input instruction - source program written in Microsoft Quick Basic® using a National Instruments Corporation GPIB-PCIIA, P.N. 320043-01 IEEE-488 Interface. It will access Model 5240, retrieve immediate data and display it exactly as received.

```
'$INCLUDE: 'c:\gpiib-pc\qbasic\qbdecl.bas'  
  CLS  
  N$ = "DEV9" ' Assign the primary address, (assume) 09.  
  rd$ = SPACE$(15) 'Make room for the data.  
  CALL IBFIND(N$,BD%) 'Subtrn Call - Init. Pri Addr.  
  CALL IBRD(BD%,rd$) 'Subtrn Call, Input data to rd$  
  PRINTrd$ 'Place it on the CRT  
END
```

If the communication checkout is functioning properly, skip the following.

DATA ACQUISITION PROBLEMS

Data acquisition problems are typically frustrating, but not difficult. The following may provide a clue to some possible causes.

- Whenever communication is complete - *and properly terminated* - the GPIB TRANSFER LED will be OFF.
- The GPIB ERROR LED simply indicates that an instruction character was not understood, *i.e.* does not match the unit's programmed set. The LED extinguishes upon acceptance of any subsequent character(s).
- If the GPIB TRANSFER LED remains ON, this indicates that communication has occurred, but the computer either has not accepted the data (probably the CR-LF) or has not released the bus for some reason. Check your interface installation software instructions. Model 5240 will probably be "hung up." You must turn the main power switch OFF (left side), *wait a few seconds*, then ON again to reestablish operation. The only time that the GPIB TRANSFER LED will remain ON - *in proper operation* - is when your program contains a continuous loop, and communication runs uninterrupted.
- If the GPIB TRANSFER LED is off, repeat the data acquisition instruction, but keep an eye on the LED to see if it flashes. If it does not flash, look for a primary address or interface hardware problem. If it flashes ON, then OFF, you are very close. Recheck your program, especially how you handle the input variable.

You may save time by contacting Magtrol Customer Service. Ask for "GPIB software assistance."

3 - Instruction Set

Before proceeding with the instruction set, some fundamental operating principles should be covered.

DYNAMOMETER CONTROL MODES

Dynamometer torque load is applied to a test motor by *either* of two modes of operation:

1. Direct torque control, where regulated and fixed current is applied to the Dynamometer Hysteresis Brake.
2. Speed control, where the immediate value of speed is compared to a reference, and brake current is proportioned to the difference.

In the speed mode (2), the Dynamometer/Model 5240 becomes a closed loop system, forcing the test motor to operate at a fixed speed. Two digital-to-analog converters form an integral part of this function, controlled by the system microprocessor. For reference within this manual, these elements are identified as Q-D/A for torque and N-D/A for the speed digital-to-analog control elements.

SPEED CONTROL RANGING

Because of the wide range of motor operating speeds accommodated, it is necessary to program Model 5240 with the test motor's maximum RPM to establish the speed range value. There are two methods to accomplish this:

1. **Non-instructed:** If the following three conditions are met, the unit will establish the correct RPM operating range automatically.
 - No previous GPIB SPEED range instruction.
 - BRAKE switch OFF.
 - Test motor installed - and running - with the dynamometer shaft speed above 256 RPM.

Model 5240 will assume the current RPM value to be the free-run motor speed, and will select and retain the correct speed range. The acceptance will be signaled by the illumination of the AUTO RANGE LED.

2. **GPIB Specified:** This method of range control has precedence, and the instruction suspends the AUTO RANGE function described above. To recover the AUTO RANGE capability, refer to the "R" or an "N" instruction. "Set An Operating Speed Range" is described below.

MODEL 5240 INSTRUCTION SET

The following is a condensed alphabetical listing of the control characters recognized by the Model 5240. The characters dddd represent a variable numerical value following the identifier. Leading zeros are not required.

A	M	PUdddS
B	M1	PR
C	M0	Q
D	N	Qdddd
E	Ndddd	R
Fdddd	O	S
H	PDdd	X
HS	PUdd	Y
Idddd	PDddS	Z

All characters must be in uppercase and ASCII format. All entries must end with a CR-LF (Hex 0D-0A), as previously outlined in the GPIB-Computer Installation, Section 2. If a string or character is not recognized, the GPIB ERROR LED will go ON. The ERROR LED will reset OFF upon a valid instruction.

SET AN OPERATING SPEED RANGE

“A” = 2,000 RPM

“B” = 4,000 RPM

“C” = 8,000 RPM

“D” = 16,000 RPM

“E” = 32,000 RPM

“Fdddd” Where ddddd is a specified speed range value between 256 and 32,000 RPM, which the motor speed is not to exceed. Leading zeros are not required. The AUTO RANGE LED will go OFF when any of the above range values are accepted.

SPEED TESTPOINT

“Ndddd” Where ddddd is any value up to 32,000 RPM. Leading zeros are not required.

Example: Force the motor to operate at 1787 RPM. Enter "N1787" (CR-LF).

The GPIB SPEED LED and SPEED SYNC LED go ON. The motor will decelerate (with some overshoot) to 1787 RPM. The SPEED SYNC LED may be somewhat intermittent, refer to Chapter 4, STABILITY CONTROL.

NOTE: If the BRAKE switch is OFF, the DYNO BRAKE LED will flash ON-OFF-ON, signaling the inability to comply with the instruction, until the brake switch is set ON.

RESET FROM GPIB SPEED CONTROL

“N” (only) Sets GPIB SPEED LED off, resets Model 5240 to the highest speed range, enabling the AUTO RANGE capability.

TORQUE TESTPOINT

In the following, the actual torque values selected (dddd) must be within the capability of the dynamometer in use. This value (full scale rating) is shown on the dynamometer front panel.

“Qdd.dd” Where the torque value in any units = dd.dd. Floating point notation, leading zeros are not required (*i.e.* d.ddd, dd.dd, ddd.d or dddd).

The GPIB TORQUE LED will go ON. The motor will be loaded to the value specified.

Example: For “Q32.5”, load the motor with 32.5 of whatever torque unit is applicable, as specified on the dynamometer front panel, *i.e.* OZ.IN., GM.CM, mNm, etc. If the BRAKE switch is off, the DYNO BRAKE LED will flash ON-OFF-ON until the switch is closed.

**RESET TO
ZERO TORQUE**

“Q” (only) Removes the torque load from the motor. The GPIB TORQUE LED will go OFF.

**APPLY FIXED
BRAKE POWER**

“Idddd” Numerical value (dddd), to be any whole number between 1 and 4095, is converted to 12 bit binary and applied directly to the Q-D/A converter. Do not use a decimal point. This results in a fixed application of voltage (and torque) on the dynamometer brake. The value (dddd) translates to 0 to 28 V.D.C. The GPIB TORQUE LED will go ON.

This instruction is a very fast method to load a motor to a specified value of torque. The value (dddd), however, must be predetermined. There will be long-term torque drift (subject to effects of hysteresis brake heating) since the function is open-loop. A method to establish an Idddd to Torque Calibration is shown in the programming examples of Appendix A.

**PROVIDE THE
IMMEDIATE Q-D/A
VALUE**

“X” This entry instructs Model 5240 that upon the next computer-read/Model 5240 write function, instead of current speed-torque data, the contents of the Q-D/A converter should be returned. The number returned will be the decimal equivalent of the binary 12 bit Q-D/A word. This information is useful when establishing a correct Idddd instruction. After the single data write instruction, the unit automatically resets to provide standard speed-torque data on subsequent write (data output) instructions. See Appendix A for further information.

APPLY FIXED SPEED

“Zdddd” dddd is converted to a 12 bit binary value and applied directly to the speed N-D/A converter. The value of dddd must be from 0 to 4095. For this instruction to work properly, the speed range A through F *must have been previously output.*

This instruction is a very fast method to load a motor to a specified value of speed. The value (dddd), however, must be predetermined. A method to establish an “Zdddd” to speed value is shown in the programming examples of Appendix A.

**PROVIDE THE CURRENT
N-D/A VALUE**

“Y” This entry instructs Model 5240 that upon the next computer-read/Model 5240 write function, instead of current speed-torque data, the contents of the N-D/A converter should be returned. This information is useful when establishing a correct “Zdddd” instruction. After the single data write instruction, the unit automatically resets to provide standard speed-torque data on subsequent write (data output) instructions. See Appendix A for further information.

**PROGRAMMED
LOAD TESTING**

“PDdd” Program Down (speed mode) from free-run to locked rotor at a rate proportional to dd. Where: dd is any number from 1 to 99, relating *indirectly* to RPM per second, where 1 is the slowest and 99 the fastest. The SPEED SYNC LED goes ON if the instruction is accepted.

The absolute rate of speed decrease, or test time, is dependent upon the free run speed of the test motor and the speed range setting. Therefore, the rate specified by “dd” must be established by test. Try 20 to start, then adjust up or down from there.

If the speed range information was *not* established prior to the instruction, the GPIB ERROR LED will go ON, indicating failure of the instruction to execute. To correct this, command an “A through F” instruction. Please note: As a rule, *either* the AUTO RANGE LED or the GPIB SPEED LED must be ON, indicating that a speed control range has been specified, in order for a “PDdd” instruction to execute.

“PUdd” Program Up at a rate of dd, same as “PDdd” except that the RPM is increasing. To be accepted, this instruction must have been preceded by an N or PD instruction.

“PDddS” or “PUddS” Same as “PDdd-PUdd” above, except that up to 500 blocks of speed-torque data are stored within Model 5240’s memory for future retrieval. This releases the host computer for other processing as a test is taking place.

In order not to overrun the memory, the total test time must be maintained under 45 seconds. As long as the memory is not overrun, multiple PD(S)/PU(S) instructions will accumulate. See “O” command and Appendix A for further information.

**CANCEL PD/PU
ROUTINE**

“PR” Resets to free run speed from a PD/PU instruction, providing the shaft is still rotating. The current speed range status is retained. If there was a previous “Ndddd” instruction, the unit will return to that. Please note that the PR instruction will fail, resulting in a locked rotor condition, if the shaft speed is below 100 RPM when the instruction is issued.

RETRIEVE MEMORY DATA	<p>“O” (not zero) This entry instructs Model 5240 to output the contents of memory obtained from a previous PDddS or PUddS function. After an “O” instruction is received, upon the next computer read cycle, instead of current Q-N data, there will be 6000 bytes of data plus CR-LF from memory. Set the input variable to 6002.</p> <p>Data in memory is retained indefinitely, even if Model 5240 is switched OFF. The memory is automatically retained, and only erased after a successful “O” command has been executed.</p> <p>Appendix A provides a programming example.</p>
SET STANDARD RESOLUTION	<p>“S” All torque data will be formatted and fixed to exactly the resolution of the dynamometer front panel torque identification.</p>
SET HIGH RESOLUTION	<p>“H” Fixes the torque resolution from that shown on the dynamometer front panel, by an additional 1/2 LS digit (0-2-4-6-8) but not greater than 1 part in 9999 resolution.</p>
SET AUTOMATIC RESOLUTION CONTROL	<p>“HS” Allows the torque value to increase resolution by 10 automatically. The decimal point will shift right or left one digit to maintain at least 1 part in 2000 resolution. This is the default mode of operation (at power up).</p>
MANUAL CONTROLS OFF	<p>“M0” (M zero) Disables the manual TORQUE and SPEED controls. The CTLS ACTIVE LED extinguishes, and the GPIB TRANSFER LED illuminates. The front panel TORQUE and SPEED control knobs are inactive.</p> <p>When using computer controlled TORQUE or SPEED functions, the “M0” instruction must precede all other control instructions.</p>
MANUAL CONTROLS ON	<p>“M1” Enables the manual torque control mode. The CTLS ACTIVE and GPIB TRANSFER LEDs illuminate. The TORQUE control knob adjusts the applied torque load.</p> <p>The “M1” followed by the “N” instruction (TORQUE and AUTO RANGE) enables the SPEED control mode. The CTLS ACTIVE and AUTO RANGE LEDs will illuminate, indicating that the SPEED control mode is active. The front panel SPEED control knob will control the speed of the test motor by applying variable loading torque to the motor (within controller and dynamometer ratings) as necessary to control speed at the set value.</p> <p>The “M” instruction toggles (reverses) all front panel control functions, <i>i.e.</i> ON to OFF and OFF to ON.</p>
RESET ALL	<p>“R” Restores the controller to the manual TORQUE control mode (mode at power turn on) and clears all previous instructions.</p>

4 - Controls, LEDs and I/O

This chapter describes the front panel control functions and indicators, rear panel Input/Output connections and controller operation.

FRONT PANEL CONTROL FUNCTIONS

TORQUE

The TORQUE control knob applies an adjustable current through the dynamometer brake coil, causing load torque application to the test motor. The TORQUE control knob is a 10-turn adjustment, capable of applying up to 0.75 amps of DC current through the brake coil. The front panel arrow indicates the direction of rotation needed to apply increasing brake torque, *i.e.* CW to increase and CCW to decrease torque application. A half turn or so of rotation may be needed before the brake starts to respond. The amount of TORQUE knob rotation necessary to obtain maximum dynamometer torque will depend on the dynamometer model used. Torque control mode is active at power turn on.

SPEED

The SPEED control provides an adjustable speed set point to which the PID (Proportional + Integral + Derivative) control loop modulates the brake current. This results in dynamic application of brake torque to maintain the motor speed at set point. The front panel arrow indicates the direction to increase (CW) or decrease (CCW) speed. Speed control permits the test motor to be controlled through most unstable regions of the motor's characteristic torque curve. Speed control mode is activated from the torque control mode, by switching the BRAKE ON/OFF switch off, then on.

The SPEED control is a 10-turn adjustment, ranging from near zero speed at the fully CCW position to the control range maximum at the fully CW setting. In speed control, the free run motor speed must be programmed into Model 5240's memory to establish the controller control range. At controller power turn on, the control range defaults to the 32,000 RPM range. This establishes the speed control set points at 32,000 RPM when the speed control knob is set fully CW and near zero at the fully CCW position. If, for example, you are testing a motor with a free run speed of 16,000 RPM, and you use the default range of 32,000 RPM, the SPEED control knob would have to be rotated approximately five turns CW before the speed control is established.

CURRENT GAIN

The CURRENT GAIN control is the outer adjustment knob of the concentric dual gain control cluster. This one-turn control adjusts the gain of the current output amplifier to provide rated torque loading from the dynamometer. Refer to the OPERATING INSTRUCTIONS - MANUAL TORQUE CONTROL section on page 17 for the adjustment procedure.

PROPORTIONAL GAIN

The PROPORTIONAL GAIN control is the center knob of the concentric dual gain control cluster. This GAIN control is the voltage gain of the proportional factor (P) of the PID speed control loop. This control is functional only in the speed control mode. The control is a one-turn adjustment of gain of the speed error signal (the difference between the set and the actual motor speed). To ensure best speed control response, the GAIN control should be adjusted for as high a gain setting as possible, while maintaining stable (non-oscillatory) motor control. The control is set in conjunction with the ERROR and the STABILITY controls.

ERROR

The ERROR control is the integral of speed error and is functional only in speed control mode. The control is a one-turn adjustment of integral gain. Increasing the integral holds the actual motor speed closer to the set point value. This control is set in conjunction with the GAIN and STABILITY control settings.

STABILITY

The STABILITY control is the negative rate feedback of brake current. Brake current is sampled by picking off a portion of the voltage drop across a 0.5 ohm current sampling resistor in series with the brake coil. Since brake torque output is proportional to current flow through the brake coil, this sampled voltage represents the applied brake torque. This torque signal is differentiated to provide a signal proportional to the torque rate of change. This negative rate signal (derivative) is algebraically summed with the PROPORTIONAL and INTEGRAL signals to provide response stabilization of motor speed. This rate feedback signal acts to improve and stabilize the test motor's response. Like the GAIN and ERROR controls, it is a one-turn adjustment, providing greater control stability, and is functional only in the speed control mode.

FRONT PANEL INDICATORS (LEDS)

The following is a detailed explanation of the front panel LED functions.

DYNO BRAKE

This is a red LED indicator which goes ON anytime the dynamometer has - *or is calling for* - torque, regardless of the BRAKE switch position. With the BRAKE switch OFF, this indication serves as notice (or **warning**) to the operator that if the BRAKE switch is closed, torque - *possibly full* - will be instantly applied, sometimes with violent results.

Another function of the DYNO BRAKE LED is to signal a GPIB instruction incapability. For example, if a speed or torque instruction is transmitted, with the BRAKE switch OFF, this LED will flash on-off-on until the BRAKE switch is turned ON.

GPIB ERROR

Anytime an unrecognizable instruction character is received by Model 5240, the unit will set this red LED ON. Additionally, if a "PD" or "PU" type of instruction is entered without previously establishing range information, the GPIB ERROR LED will go ON. Any valid instruction received after the LED is ON will clear the error indication.

GPIB TRANSFER

While Model 5240 is either receiving or sending data, this amber LED is turned ON. It remains on for 1/2 second after GPIB ceases activity.

If Model 5240 or the host computer should "hang-up," and this LED remain on, it indicates that a GPIB communication transfer was incomplete. Look for a missing CR-LF from the computer to Model 5240, early computer sign-off, or other software or hardware defect. For more information on this, turn to Section 2, SOFTWARE INSTALLATION.

SPEED SYNC

When this amber LED is ON, the shaft RPM is within a few RPMs of an "Nddddd" specified value, or a PU/PD instruction has been accepted and is in progress.

AUTO SPEED RANGE

This green LED signals that Model 5240 is in SPEED control and has set the free run speed of the test motor automatically.

GPIB TORQUE

This green LED signals that the unit is presently operating under a computer-directed torque control mode of operation. The “Q” or “T” type of instruction sets this mode. If the manual TORQUE control is active, it can override the GPIB instruction.

GPIB SPEED

This green LED signals that the unit is operating under a computer-directed speed control mode, and that the operating speed range is established. All “A through F” or “N” type of instructions will turn this LED ON. AUTO SPEED RANGE control is disabled, regardless of the brake switch setting. If the manual SPEED control is active, it can override the GPIB instruction.

CTLS ACTIVE

This green LED signals that the unit will accept manual TORQUE control. If the TORQUE control is deactivated by a GPIB instruction, “M0”, the CTLS ACTIVE LED will be off.

MODEL 5240 ELECTRICAL I/O

The following is a description of the electrical Input/Output. All connectors are contained on the rear panel of Model 5240.

GPIB INTERFACE

Computer to instrument interconnection uses the standard IEEE-488 Instrument Cable available from instrumentation cable manufacturers, computer hardware outlets, Magtrol, Inc., or Hewlett Packard dealers.

The following is a brief description of the interface lines. For more thorough information, various publications on the IEEE-488 are available from Intel, Motorola, IEEE, National Semiconductor and Hewlett Packard, to name a few. Two bytes form the composition of the GPIB, 8 bits for data transfer and 8 bits for interface control.

D1-D8 Data signal lines. The data format is 8 bit ASCII.

DAC, RFD, DAV are byte transfer lines:

RFD Ready For Data, goes passively high.

DAV Data Valid - an instrument may signal that its data is valid by pulling this line low.

DAC Data Accepted - will go passively high, signaling that the data has been accepted.

IEEE-488 INTERFACE

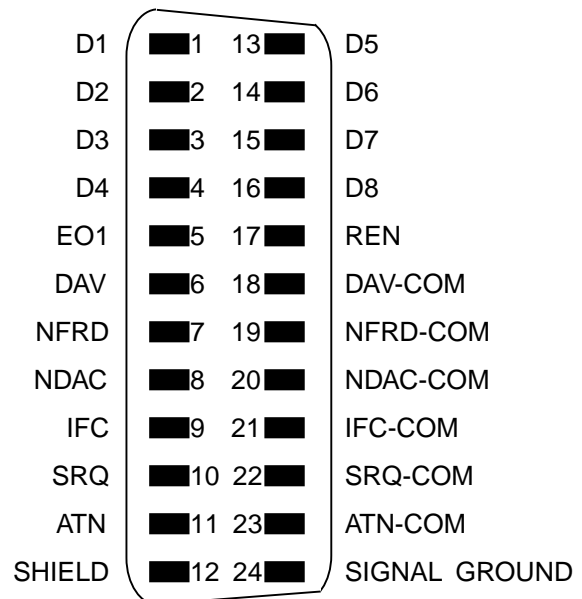

ATN, IFC, SRQ, EOI, REN are bus management lines that control the orderly movement of information across the interface lines:

- ATN** (Attention) monitored continually, and a change results in activation of the transmit/receive control signals.
- IFC** Interface clear - used by the system controller to place the GPIA (General Purpose Interface Adapter chip) into a known quiescent state.
- SRQ** Service request signals a need for service by requesting the controller to interrupt the current sequence of events.
- REN** Remote Enable - selects an alternate source for device programming data. This converts the GPIA into another state of operation.
- EOI** End or Identify - has a dual purpose. It may signal the end of a multibyte transfer, or when used in conjunction with ATN, places the contents of the parallel poll register on the bus.

DYNAMOMETER BRAKE



Model 5240 applies power to the dynamometer load brake through a cable fitted with Cinch type, 2 pin connectors. These lines connect directly to the dynamometer hysteresis brake coil in Magtrol Dynamometer Models HD-100, HD-106, HD-400, HD-500, HD-700 and HD-705. On Models HD-800 and up (HD-8XX), an intermediate booster power supply is contained within the dynamometer cabinet. The applied voltage is 0-28 VDC, at up to 0.7 amps, dependent on dynamometer size.

ACCESSORY TORQUE-SPEED OUTPUT

This is an output only connector. It is used to provide input to other Magtrol Digital Torque-Speed products. The connector is a standard 7 pin DIN type.

D.P. Pin 7, D.P. Pin 3: These are decimal point locator lines. They have pull-up resistors to +5VDC. Each individual dynamometer will have the appropriate line connected to ground that codes the decimal point location for Model 5240 and other Magtrol products. The decimal point locator code is:

- ddd.d = Pin 7 HI, Pin 3 HI.
- dd.dd = Pin 7 LO, Pin 3 HI.
- d.ddd = Pin 7 HI, Pin 3 LO.

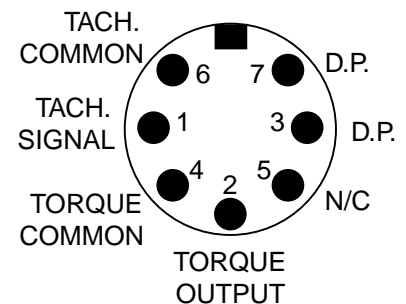

Tachometer Signal: This is a TTL compatible standard frequency output of 60 pulses per shaft revolution. Outputs of 600 or 6,000 pulses per revolution are available on special order. The tachometer common is chassis ground.

Torque Output: This is a bipolar analog voltage. The torque common is chassis ground. The torque signal amplitude varies with the individual dynamometer connected to Model 5240. The signal is equal to the whole number of the torque value (identified on the dynamometer front panel) in millivolts. Positive polarity would indicate torque applied in CW direction of rotation. For example: for an HD-700-6 with full scale torque applied in a CW direction, torque = 425 oz.in. and 0.425 volts between pins 4 and 2, with pin 2 positive.

ACCESSORY CABLE

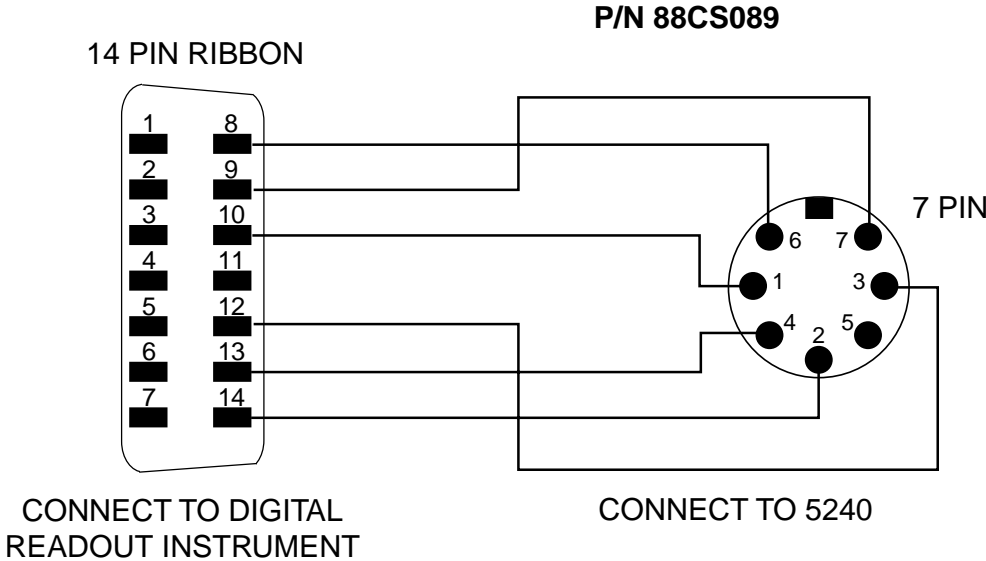

The cord set required to connect Model 5240 to another Magtrol Digital Readout is Magtrol P.N. 88CS09. This has a 7 pin DIN connector on one end, with a 14 pin ribbon connector on the other. *Do not* use this cord set to connect a dynamometer to Model 5240. No damage will result, but nothing will work!

DYNAMOMETER

Model 5240 connects to any Magtrol dynamometer with a 14 pin ribbon connector.

Pin 11 is a spare 10 VDC used in older dynamometers.

Pin 10 is the tachometer frequency signal providing 60 pulses per shaft revolution. The signal level has a low voltage of approximately 0.2, and a signal high of $5.0 + 0.1$ VDC. The common to this signal is Pin 8.

Pin 14 is the millivolt level torque signal, referenced to **Pin 13**. This is a bipolar analog voltage. Pin 13 (common) is chassis ground. The torque signal amplitude varies with the individual dynamometer connected to Model 5240. It is equal to the whole number of the torque value (identified on the dynamometer front panel) in millivolts. Positive polarity would indicate torque applied in CW direction of rotation. For example: an HD-106-6 with full scale torque applied in a CCW direction, torque = 2.50 oz.in. = 0.250 volts between pins 14 and 13, with pin 14 negative.

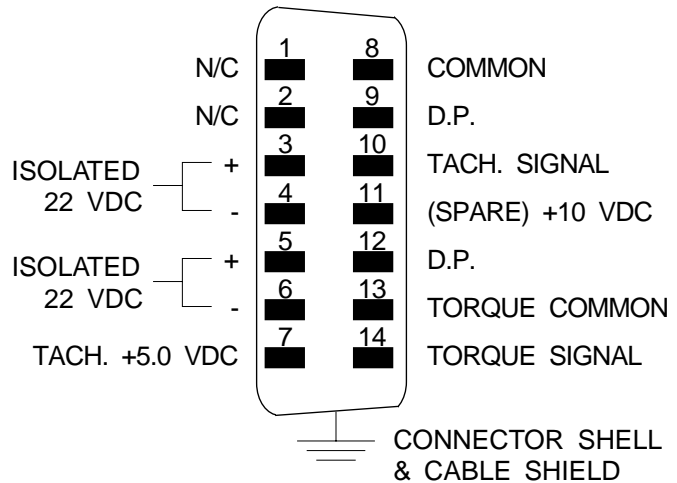

Pins 9 - 12 are decimal point locator lines. Each individual dynamometer will have the appropriate line connected to ground that codes the decimal point location for Model 5240 and other Magtrol products. The decimal point locator code is:

ddd.d = Pin 9 N/C, Pin 12 N/C.

dd.dd = Pin 9 LO, Pin 12 N/C.

d.ddd = Pin 9 N/C, Pin 12 LO.

Where N/C = no connection, LO = Common to Pin 8.

Pin 7 is 5.0 VDC for the TACH LED/Phototransistor. It references common to **Pin 8** as shown.

Pins 3-6 are 20 VDC isolated instrumentation voltages for the torque signal amplifiers and the torque load cell power supply. Within the dynamometer enclosure, these unregulated voltages are converted to regulated + 15 VDC and regulated + 5.0 VDC for the dynamometer torque transducer load cell. Your Dynamometer User's Manual Chapter 4 covers this in greater detail.

OPERATING INSTRUCTIONS

NOTE: Please refer to the Instruction Set description in Section 3 for a complete listing and description of all available instructions.

MANUAL TORQUE CONTROL

Preset the TORQUE knob fully CCW and the BRAKE ON/OFF switch ON. Turn the power ON. The CTLS ACTIVE LED should illuminate, indicating that the controller is in the manual TORQUE control mode.

The CURRENT GAIN control is adjusted to supply dynamometer coil current sufficient to provide rated shaft torque. This is set as follows:

1. Attach the Calibration Beam supplied with your Dynamometer to the load shaft. The Calibration Beam is simply a moment arm that converts a force from a weight hung at a specific distance to a calibrated torque applied to the load shaft. The load torque is the weight times the moment arm distance. See the sketch in the FULL SCALE TORQUE CALIBRATION paragraph on page 22.

For example, an HD-705 is rated 50.0 lb.in. load torque. Hanging a 5.00 lb. calibrated weight at the 10 inch pin of the Calibration Beam applies the rated torque of 50.0 lb.in. to the dynamometer shaft. The Calibration Beam is marked in inches for an English system of units or centimeters for metric.

2. Set the front panel manual TORQUE control for maximum torque - fully clockwise. Set the CURRENT GAIN control (outer knob of GAIN control cluster) for minimum current - fully counterclockwise.
3. Slowly increase the CURRENT GAIN control clockwise while holding the calibration weight on the Calibration Beam's hanging pin until the dynamometer torque is just sufficient to support the weight when the beam is horizontal. The Calibration Beam should be positioned horizontally as determined by the bubble sight glass located at the center of the Calibration Beam.

Make a note of the position of the CURRENT GAIN control knob for future calibration reference. The controller is now calibrated to supply full dynamometer load torque when the manual TORQUE control knob is set fully clockwise. This calibration is also active when operating the controller from computer control. Therefore, this setting should be maintained in both MANUAL and COMPUTER control modes.

NOTE: The CURRENT GAIN control setting can be modified from the calibrated setting to achieve optimum control response while running an automated motor test curve. This will not affect the calibration numbers, only the control response. If a readjustment has been made, return the CURRENT GAIN knob setting back to the calibrated reference position when the test is completed.

Adjusting the TORQUE control knob will apply an adjustable torque load to the test motor. Set the motor load as desired within the dynamometer and motor specifications.

The GAIN, ERROR and STABILITY controls are non-functional since they are speed control adjustments.

Manual torque control can be started from the GPIB TORQUE or GPIB SPEED control modes by sending an “R” (reset) GPIB instruction.

NOTE: Be careful not to stall or overload the motor, as damage to your motor could result.

GPIB TORQUE CONTROL (COMPUTER CONTROL)

Set the CURRENT GAIN control as described in the MANUAL TORQUE CONTROL paragraph, above.

To initiate GPIB computer interface control, enter the “M0” (M zero) command. The CTLS ACTIVE LED will extinguish, and the GPIB TRANSFER LED will illuminate. A torque control value (within the ratings of your dynamometer and motor) can be set by sending the “Qdd.dd” instruction (dd.dd is the torque value). The GPIB TORQUE, GPIB TRANSFER and DYNO BRAKE LEDs should illuminate. Use the “Q” instruction to remove (zero) the torque load. The GPIB TORQUE and DYNO BRAKE LEDs will extinguish, and the GPIB TRANSFER LED will illuminate.

When in GPIB TORQUE control, other modes can be entered as follows:

MANUAL TORQUE control can be restarted by using the “R” (reset) instruction, the CTLS ACTIVE LED should illuminate. See the MANUAL TORQUE control section, above.

MANUAL SPEED control can be started using the “R” (reset) instruction, followed by sequencing the BRAKE ON/OFF switch OFF and ON. The AUTO RANGE LED should illuminate. See the MANUAL SPEED CONTROL section, below.

GPIB SPEED control can be started from the MANUAL SPEED control mode by using the “M0” (M zero) instruction. See the GPIB SPEED CONTROL section, below.

MANUAL CONTROL

The controller’s AUTO RANGE feature will establish the speed range calibration as follows:

1. Preset the PID control knobs as shown:
SPEED - fully CW
GAIN - to approximately the 9:00 o’clock position
ERROR - to approximately the 9:00 o’clock position
STABILITY - to approximately the 9:00 o’clock position
2. Sequence the BRAKE ON/OFF switch OFF and ON. The AUTO RANGE LED will illuminate. This uses the controller’s auto range capability to establish the speed range at the free run motor speed. The speed control range is now set from near locked rotor (zero) to the free run speed. As long as the BRAKE switch remains ON, the set speed range will remain in effect.
3. Rotate the SPEED control knob CCW to apply a load torque to the brake, slowing and controlling motor speed at the set value. Continue to slowly turn the SPEED control CCW through the desired

speed range and observe its performance. If the motor speed is unstable (oscillatory) or if you wish to fine tune the controller for optimum performance, see the PID control loop setting procedure below.

Setting the PID Control Loop for Optimum Performance

These adjustments should be made after the speed range has been set (see step 2 above).

- A. If the motor speed is oscillatory, rotate the STABILITY control to achieve stability. If good stability cannot be achieved, reduce the GAIN setting and readjust the STABILITY control. Work back and forth between the STABILITY and GAIN controls to achieve good stability. If the speed response is too slow, increase the GAIN control CW and readjust the STABILITY control to maintain stability.
- B. With a stable motor, peak performance can be obtained by adding more proportional GAIN (CW) and readjusting the STABILITY control as necessary to maintain good motor stability. Add some integral by turning the ERROR control a little CW, and readjust the STABILITY control as necessary to maintain good motor stability. Work back and forth with the GAIN, STABILITY and ERROR controls to optimize motor response performance. A little experimentation will be necessary to get the feel of the adjustment effects. The goal is to achieve settings of the GAIN and ERROR controls as far CW as possible and still have good motor stability throughout the desired motor speed range.

The higher (CW) the GAIN is set, the more responsive the control will be, and the higher (CW) the ERROR control is set, the closer the speed will be held to the set point value. The best PID control loop settings will be achieved by alternately working back and forth with the above controls, while varying the motor speed through the desired speed range.

GPIB SPEED CONTROL (COMPUTER CONTROL)

1. Set the speed PID loop controls of GAIN, ERROR and STABILITY, as in manual speed control mode, above. These manual speed control settings are a good starting point for the GPIB speed control mode settings. From these, you can fine tune the GAIN, ERROR and STABILITY settings as needed to achieve the desired response. If the speed control range under the GPIB mode runs from near locked rotor to free run, make sure that you manually vary the speed from free run to near zero speed while making your manual speed settings. The wider the desired speed control range, the more critical the PID control settings become, *i.e.* to control from near locked rotor to free run requires the most fine tuning.
2. From the Manual Speed Control Mode, use the “M0” (M zero) instruction to start the GPIB computer speed control mode. The GPIB TRANSFER and GPIB SPEED LEDs should illuminate.
3. Establish an operating speed control range by using the “Fddddd” instruction, where ddddd is a specific range value between 256 and 32,000. The AUTO RANGE LED will extinguish. In general, you will want to set the speed range to the free run speed of your test motor.

The operating speed range can also be set by using one of the five preprogrammed ranges as shown:

- Instruction “A” sets the range to 2,000 RPM.
- Instruction “B” sets the range to 4,000 RPM.
- Instruction “C” sets the range to 8,000 RPM.
- Instruction “D” sets the range to 16,000 RPM.
- Instruction “E” sets the range to 32,000 RPM.

-
4. Speed set points are set by using the “Nddddd” instruction. The SPEED SYNC LED illuminates when the set point is reached. If the SPEED SYNC LED fails to illuminate, the speed is not within an acceptable error from the set value. If this happens, try increasing the GAIN and ERROR control settings (CW). If the SPEED SYNC LED flashes on and off, the motor is oscillating. The STABILITY control setting should be increased (CW) and the GAIN control may possibly need to be reduced (CCW) to achieve stability.
 5. To cancel an existing speed range (GPIB SPEED LED is on), use the “N” instruction. This instruction sets the speed range to the maximum range of 32,000.
 6. From GPIB SPEED CONTROL Mode, other modes can be entered as follows:

GPIB TORQUE control can be started by using the “N” and “Qdd.dd” instructions. See the GPIB TORQUE control operating instructions, above.

MANUAL TORQUE control can be started by using the “R” (reset) instruction. See the Manual Torque control operating instructions, above.

MANUAL SPEED control can be started by using the “R” (reset) instruction, followed by sequencing the BRAKE ON/OFF switch off and on. See the Manual Speed control operating instructions, above.

5 - Calibration

Calibration and balancing controls are provided for most of the analog elements in Model 5240. Normally, no adjustment of these elements is anticipated for the life of the instrument. All or part of the calibration and balancing procedures may be indicated, however, if any of the following conditions exist:

- Slight torque loading, with the DYN0 BRAKE LED ON, *when not called for*.
- A torque difference between the GPIB indicated value and another Magtrol Digital Readout of greater than $\pm 0.25\%$.
- A torque difference between CW and CCW full scale readings of greater than 2 least significant digits in standard resolution.

There is no calibration for the digital speed reading. Please refer to MODEL 5240 SPECIFICATIONS in this chapter.

BEFORE PROCEEDING

Routine Torque calibration and zero offset adjustments should always be done using your dynamometer. The torque signal offset and calibration controls within Model 5240 are provided to permit standardization with other Magtrol Digital Readouts, as well as agreement between full scale values in both CW and CCW directions.

The torque value produced by the dynamometer should read within tolerance on all instruments. If a dissimilarity exists between Model 5240 and another digital readout, before proceeding with zero offset or calibration adjustments, you must establish *which* of the two instruments requires the service adjustment. This must be done first, by standardization of the dynamometer signal output.

WARNING! The following requires removal of Model 5240's top cover. All connections and trimpot adjustments must be made only as specified herein and with **caution**. There is an **electrical shock hazard** inside Model 5240. Do not touch or connect instrumentation to any elements of the circuit boards, front panel or chassis components.

All calibration and balancing potentiometers are contained on the circuit board identified 78B159. This is located in the lower left corner of Model 5240's chassis, facing from the rear panel. The following sketch shows the portion of the board on which the trimpots are located, their identification and function.

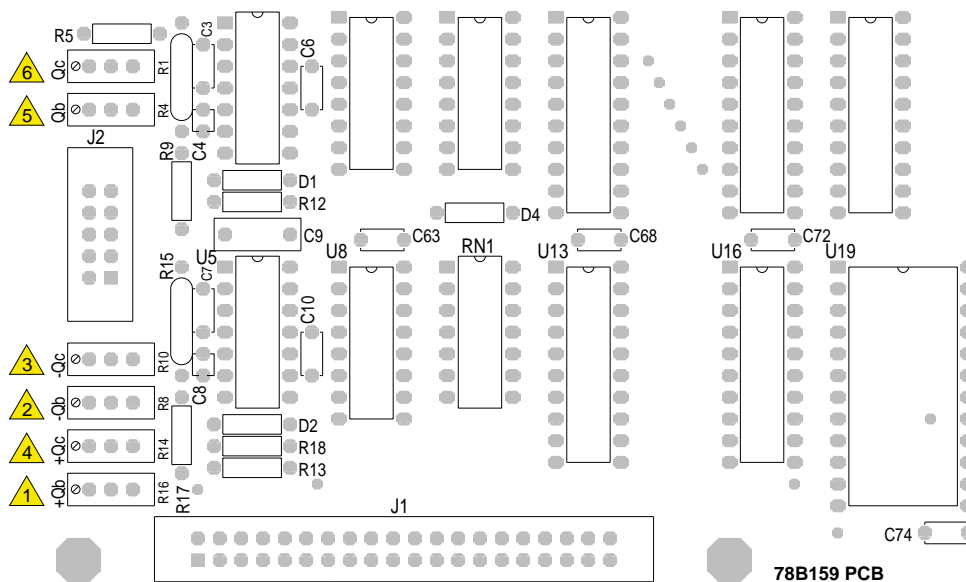

TRIMPOT FUNCTION



- $Q_c R_1$ - Accessory output torque calibration (Q_0 Cal).
- $Q_b R_4$ - Accessory output torque signal zero (Q_0 Bal).
- $-Q_c R_{10}$ - CCW torque full scale calibration ($-Q_{Cal}$).
- $-Q_b R_8$ - CCW torque zero ($-Q_{Bal}$).
- $+Q_c R_{14}$ - CW torque full scale calibration ($+Q_{Cal}$).
- $+Q_b R_{16}$ - CW torque zero ($+Q_{Bal}$).

To perform the following, you must write a short, continuous loop program to have Model 5240's Torque output reading displayed by the controlling computer. All references to "CRT" in the following pertain to this reading. APPENDIX A contains a short program example, CONTINUOUS Q-N DISPLAY, for your reference.

TORQUE ZERO (NULL) ADJUSTMENT

1. Remove any couplings from the dynamometer shaft.
2. Place a precision voltmeter resolving at least 0.1 millivolt (DC) between pins 13 and 14 on the DYNAMOMETER ribbon connector, pin 13 negative. You may have to remove the connector cap on the cable or obtain access from inside the dynamometer rear panel.
3. Adjust the dynamometer zero control for best zero (dynamometer torque signal output) on your voltmeter.



The object of the following step is to alternate between the - and + **Bal** trimpots ($-Q_b$ and $+Q_b$, respectively), until you know that each is adjusted so that your output torque reading is **JUST** at zero - on *both* trimpots. While observing, Model 5240's Output Torque Reading (CRT):

4. Adjust the + **Q Bal** trimpot ($+Q_b$, R_{16})  slowly. Try both CW and CCW rotation until the indicated torque value reads higher, then back off very slowly until the reading is zero or returns to the original value. Repeat this procedure on the - **Q Bal** trimpot ($-Q_b$, R_8) . Work back and forth to set zero with a 1 flashing occasionally.

FULL SCALE TORQUE CALIBRATION

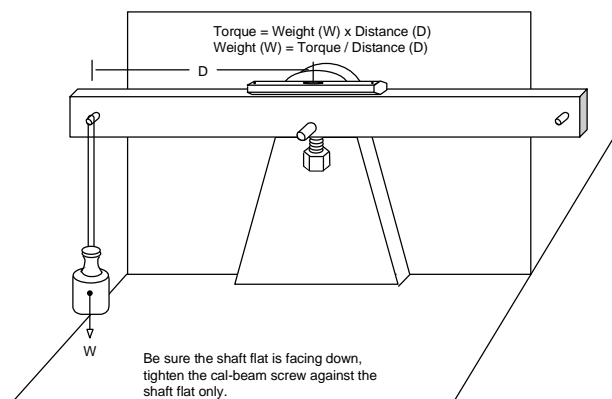
1. Complete the zero adjustment procedure outlined in the preceding section. Install the Dynamometer Torque Calibration beam, as shown in the sketch.





-
2. With Model 5240 in MANUAL TORQUE mode, turn on the BRAKE switch. Rotate the TORQUE control full CW for maximum applied torque. With a precision weight, apply a known torque at or close to full scale in the CCW direction. Maintain the beam exactly horizontal and perfectly still.
 3. Observe the voltage reading (across pins 13 and 14) on the voltmeter. Adjust the TORQUE CALIB on the rear panel of the dynamometer for a voltmeter (millivolt) reading exactly equal to the true torque applied.
 4. Adjust the $-Q_{\text{cal}}$ trimpot ($-Q_c, R_{10}$)  until Model 5240's output (CRT) torque reading is equal to the voltmeter reading.
 5. Place the weight on the opposite side of the beam. Adjust the $+Q_{\text{cal}}$ trimpot ($+Q_c, R_{14}$)  to match Model 5240's output (CRT) torque and voltmeter reading.

NOTE: As you changed the torque direction, if there is an excessive CW to CCW difference (greater than 2 LSD at standard resolution), this may indicate a need to adjust the pivot bearing assembly within the dynamometer. Before doing this, however, be sure your voltmeter repeats a reading after a polarity reversal. *Many do not.* Please consult Dynamometer Customer Service at Magtrol before attempting mechanical alignment of the dynamometer pivot assembly.

ACCESSORY TORQUE OUTPUT CALIBRATION

With zero torque applied to the dynamometer and nothing connected to the shaft:

1. While reading Model 5240's output (CRT) torque value, adjust the dynamometer ZERO control for best zero reading.
2. With a voltmeter, resolving at least 0.1 millivolt DC, connected between pins 2 and 4 on the ACCESSORY TORQUE-SPEED OUTPUT connector, or using the Magtrol Digital Readout Instrument, adjust the Q_0 Bal trimpot (Q_0, R_4)  for best zero reading.
3. Attach a Calibration beam. Energize the brake to hold the beam. Attach a weight to apply an amount of torque close to the dynamometer full scale rated value. Adjust the Q_0 Cal trimpot (Q_c, R_1)  for the correct torque reading.

MANUAL TORQUE CONTROL ZERO

1. At zero RPM, rotate the TORQUE control 1/2 turn CW (ON).
2. Rotate the TORQUE ZERO trimpot R_{33} until the DYNO BRAKE LED *just* goes ON, then CW until it *just* goes OFF.

GPIB "Q" COMMAND TORQUE NULL

1. Output an "I16" command to Model 5240.
2. If the DYNO BRAKE LED is OFF, no adjustment is necessary. If the DYNO BRAKE LED is ON, adjust the Q trimpot until the LED *just* goes out.

This completes the balancing and torque calibration procedure.

MODEL 5240 SPECIFICATIONS

SPEED CONTROL

OUTPUT: DC speed control current up to 0.75 amps.

ACCURACY: $\pm 0.05\%$ of the SPEED reading.

RESOLUTION (in RPM):	<u>RANGE</u>	<u>RESOLUTION</u>
	0 to 4,000	1.0
	0 to 8,000	2.0
	0 to 16,000	4.0
	0 to 32,000	8.0

TORQUE CONTROL

OUTPUT: DC torque control current up to 0.75 amps.

ACCURACY: Determined by the accuracy of the dynamometer in use. Please refer to your Magtrol Dynamometer User's Manual for detailed specifications.

POWER: 120 Vrms or 240 Vrms, 48 to 63 Hz at 120 volt amps.

A WORD ON SPEED VARIATIONS

Instantaneous speed measurements, required for rapid data acquisition, produce some aspects of motor shaft velocity not normally encountered with typical averaging methods of RPM indication.

A factor encountered in most induction motors, and all motors to some extent, is the lead/lag of the rotor in relation to the magnetic field that pulls it. You might visualize the rotor connected to the pulling force by a rubber band, resulting in a slow rotational oscillation, rate dependent upon the rotor's inertia and other factors. This is a *change in velocity occurring within a single revolution*.

With velocity measurement extracted from only a few degrees of rotation, and not necessarily in a fixed radial position (speed is variable), the measurement window will occur at random locations of the rotor's angular position. Therefore, when a reading is "snapshot," it may be higher or lower than the longer term averaged speed.

These combinations can produce velocity variations, appearing as data scatter. These may occur rapidly or sometimes very slowly.

One of the more startling examples occurs when a synchronous induction motor displays a motor speed greater than the synchronous speed! No, this is not an inaccuracy, and not to despair, if the data is averaged over a sufficient time period, such as one to two seconds (10 or 20 readings is usually adequate), the variations will integrate, resulting in an RPM precisely equal to the synchronous speed.

While we may not like these variations, they really represent what the motor is doing within the short time frame we use to control and produce data.

6 - Circuit Description

TACHOMETER

Simultaneous analog and digital speed data is required for proper function of Model 5240. Digital format is required for RPM as data, analog for the dynamometer speed control signal. Both signals must be highly responsive and noise free.

PCB No. 78B156 is the tachometer section which produces this speed information. It uses a clock which is gated on-off by the period of time between pulses generated by the tachometer generator. Because of the overall RPM range (0-32,000), the time period must be selectively staged and is dependent upon the immediate shaft speed - between 1, 1/10 or 1/60 of a shaft revolution.

Since RPM is now a reciprocal value, a math function is required to convert the value back to true RPM. All functions are under command of a microprocessor that performs ranging decisions, math and calibration processes in microseconds.

The block diagram identifies the basic elements. The MPU section contains a Programmable Read Only Memory (PROM) and Peripheral Interface Adaptor (PIA) for program and I/O control. It also contains buffers and other “hand-shaking” elements.

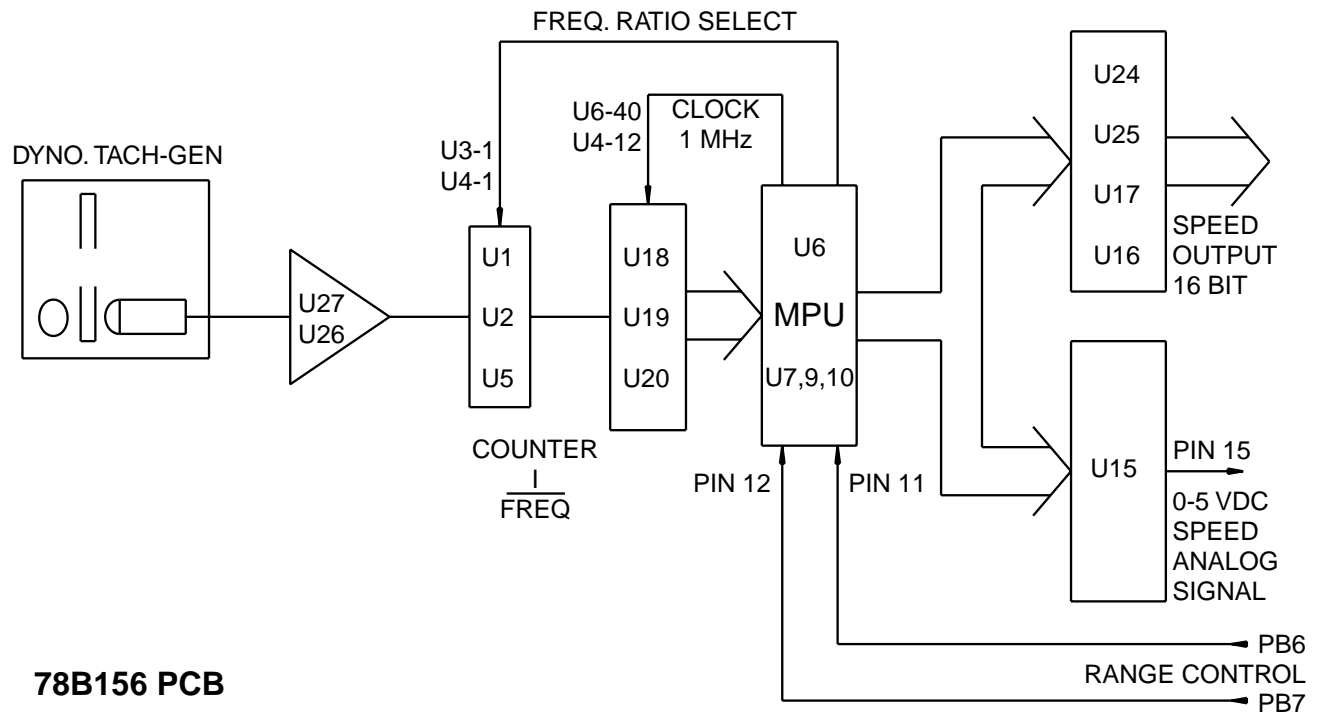

The speed transducing function is complex, and only elemental measurements for adequate power supply voltages and speed signal output may be done easily. The analog speed output signal may be measured between pin 15 and 17 on U15. This voltage is between 0 to 5.0 VDC, full scale, for each speed range. If a voltage proportional to speed is present here, you can reasonably assume that everything in the speed section is working properly.

SPEED CONTROL

GPIO SPEED CONTROL

This functional block diagram shows the speed PID control section and the current output amplifier, both located on PC board 78B159.

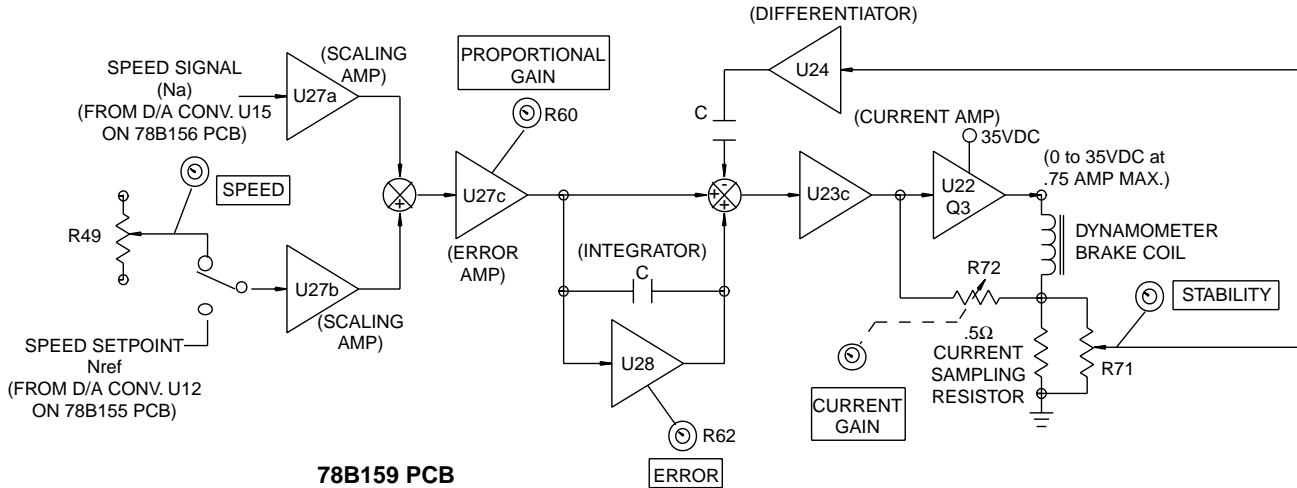

The calibrated speed signal, N_a , from D/A (digital to analog) converter U_{15} (located on the 78B159 PC board) and the speed command set point N_{ref} from D/A converter U_{12} (located on the 78B159 PC board) are algebraically summed and amplified by operational amplifier U_{27c} . The amplification of this speed error signal is controlled by the front panel proportional GAIN control potentiometer R_{60} . This speed error signal feeds an integrating operational amplifier U_{28} . The amount of integral signal is adjusted by the front panel integral ERROR control potentiometer R_{62} . Brake current is sampled by a 0.5 ohm series resistor, amplified and differentiated by operational amplifier U_{24} . This derivative signal is proportional to the rate of change of brake current and acts as negative rate feedback to provide stability and response shaping. The amount of rate feedback is adjusted by the front panel derivative STABILITY control potentiometer R_{71} . Then, the proportional speed error signal from U_{27c} , the integral signals from U_{28} and the derivative signal from U_{24} are algebraically summed by operational amplifier U_{23c} to produce the PID (proportional plus integral plus derivative) control signal. This PID control signal is input to a current feedback amplifier composed of operational amplifier U_{22} and bipolar power transistor Q_3 , both connected in a current feedback configuration with the brake control coil. This same current amplifier is utilized during manual and computer torque control. The current amplifier gain is adjusted using front panel potentiometer R_{72} . This PID current signal modulates the torque (torque from a hysteresis brake is proportional to brake current) applied to the test motor to achieve closed loop speed control of the test motor. For example, if the motor speed is above the set speed, the PID loop increases brake current until the increasing applied torque causes the motor to run at the lower set speed. Conversely, if the motor speed is less than the set value, the PID loop reduces brake current until the reducing applied torque causes the motor to run at the higher set speed. Any deviation from the set speed causes the PID control loop to apply a compensating current to correct for the deviation. The time response and amount of this correction are determined by the settings of the GAIN, ERROR and STABILITY controls.

MANUAL SPEED CONTROL

In manual control, the speed set point comes from a regulated DC voltage applied through the front panel SPEED potentiometer R_{49} . This signal is used in place of the N_{ref} signal from the U_{12} D/A converter as described by the above GPIB SPEED CONTROL paragraph. Circuit functionality is otherwise identical to the GPIB SPEED CONTROL description above.

TORQUE CONTROL

GPIB TORQUE CONTROL

The following functional block diagram shows the torque control section and the current output amplifier, located on PC Board 78B159.

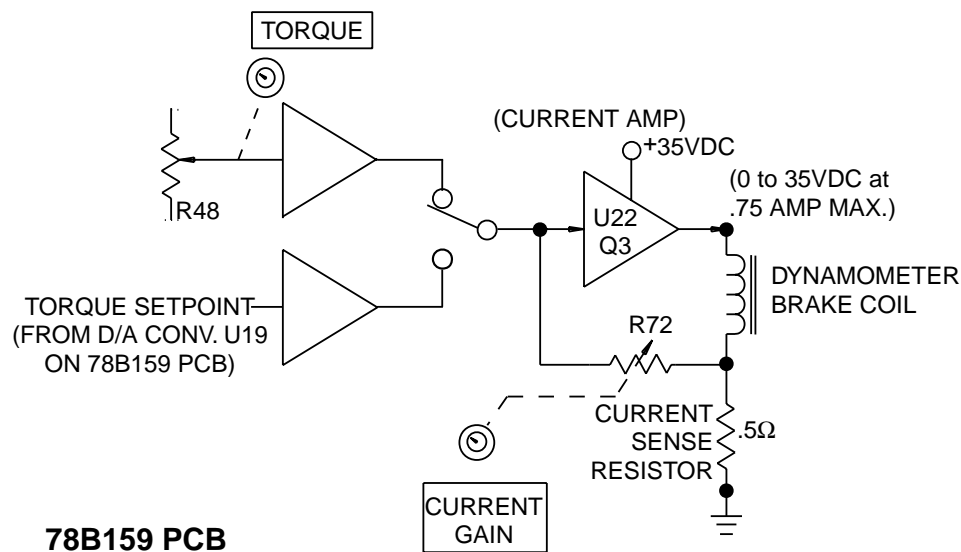

A computer-generated torque signal from D/A converter U_{19} , located on the 78B159 PC board, is applied at the input of a linear current output amplifier. The current amplifier is composed of operational amplifier U_{22} and bipolar power transistor Q_3 , connected in a current feedback configuration with the brake control coil. The current gain is adjusted by the front panel CURRENT GAIN potentiometer control R_{72} (outer knob) to provide rated dynamometer shaft torque for full D/A control input voltage. When a torque instruction ("Qdd.dd" or "Idddd") is entered, the D/A converter's (U_{19}) output is adjusted by the microprocessor to provide a voltage input to the current amplifier to produce the torque value (dd.dd or ddddd) of the instruction. Therefore, a digital control loop is closed, providing regulating load torque at the instruction set point value to the test motor.

MANUAL TORQUE CONTROL

In manual control, the microprocessor-generated torque signal from the D/A converter is replaced by a regulated DC voltage applied through the front panel TORQUE potentiometer R_{48} . This voltage is applied to the input of the same current output amplifier as described above for the GPIB TORQUE mode. Therefore, the TORQUE control provides an open loop adjustment of brake current to produce the load torque applied to the test motor.

SALIENT POLE "COGGING"

If a specified torque level cannot be maintained (stalled motor), then the system will saturate and load the brake - full on. A hysteresis brake, with current applied, in the absence of rotation, will temporarily exhibit salient poles when the power is subsequently removed. Your Magtrol Dynamometer User's Manual contains a description of this effect, sometimes referred to as "cogging."

I/O AND MAIN DATA PROCESSING

The primary MPU and GPIB controlling electronic functions are contained on PC board 78B155. On this assembly, U5 is the microprocessor, and U10 is the Programmable Read Only Memory containing the Model 5240 operating system. A 2K nonvolatile RAM device is identified as U11. The N-D/A speed reference D/A is U12. U13 and U14 are Peripheral Interface Adapters. U1, U2 and U3 are the GPIB interface control elements. The balance of the components are buffer and timing control devices.

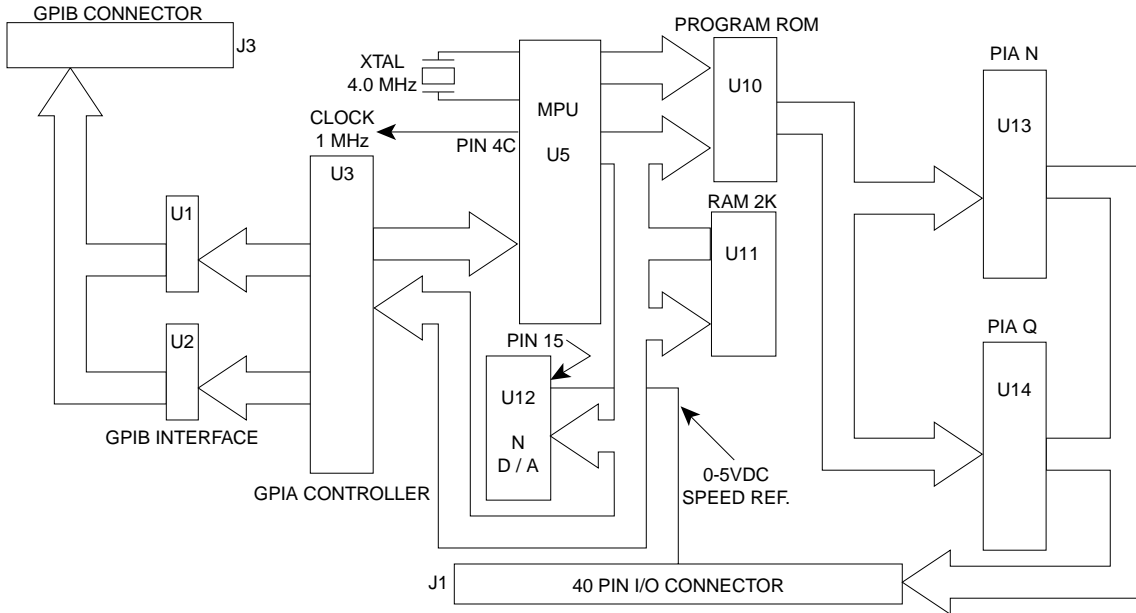

PC board 78B157 power supply provides +5 logic power, +15 volts for the analog elements and a 35 VDC-50 watt source of power for the dynamometer brake.

Hysteresis brakes, used on all Magtrol Dynamometers, are 28 VDC units.

If you have questions or require more detailed information, please contact Magtrol Customer Service Department, Dynamometer Technical Information.

APPENDIX A: Programming Examples

MAGTROL MOTOR TEST SOFTWARE

Magtrol offers, as an option, a comprehensive motor test software package available on either 3-1/2" floppy disks or CD-Rom. To demonstrate the capabilities of this package, a free demo disk is also available. For further information, or a copy of the demo disk, contact Magtrol Sales at 716-668-5555 or visit our web site at:
www.magtrol.com

Most people involved in computer programming are familiar with BASIC. In order to show the programming techniques as simply as possible, all of the following examples are given in Microsoft 4.5®, using a National Instruments GPIB-PC2A interface.

If you are using another IEEE-488 interface system, modification of the assembly language CALL subroutines will be required.

Except for the SPEED-TORQUE CRT DISPLAY program, immediately following, the primary address used in all examples is the default factory setting of 9. If you modify the code switch setting, you will have to correct the “dev9” operands to reflect this change. Look for the line BDNAMES\$ = “dev9” and modify the 9 to whatever you selected, *i.e.* 1 through 15.

SPEED-TORQUE CRT DISPLAY

In the following example, the program will ask for the GPIB primary address. If you have not changed it, enter 9, and the speed-torque values should display on the CRT, updating continuously:

```
'$INCLUDE: 'c:\gplib-pc\qbasic\qbdecl.bas'
CLS : LOCATE 10, 20
INPUT "Enter the primary address (1-15)...", an$
BDNAME$ = "DEV" + an$
CLS
CALL IBFIND(BDNAME$, BD%) 'Initialize the GPIB
rd$ = SPACE$(15) 'Dimension the input
DO:
CALL IBRD(bd%, RD$)
    spd = VAL(MID$(rd$, 2, 5)) 'Extract N
    tor = VAL(MID$(rd$, 8, 5)) 'Extract Q
LOCATE 10, 20: PRINT "Speed = "; spd
LOCATE 11, 20: PRINT "Torque = "; tor
LOCATE 20, 50: PRINT "Any key ends..."
LOOP WHILE INKEY$ = ""
SYSTEM : END
```

RECALL MODEL 5240 DATA FROM MEMORY

If a PDddS or PUddS instruction was issued, all data from the test run will be retained in Model 5240's memory, provided that the total test time did not exceed 50 seconds (500 test points @ 0.1 sec.) Another PDddS/PUddS instruction will append data to that already in Model 5240's memory. The memory is cleared only when an "O" command is issued and the data transfer successfully completed.

In the following program fragment, the variable QNdata\$ receives the test data from Model 5240 memory. The data format is similar to that shown on page 2-3, *except that the shaft direction character (L or R) is eliminated*. Each individual test point block is always 12 characters long.

```
'$INCLUDE: 'c:\gpib-pc\qbasic\qbdecl.bas'  
'Routine to access Model 5240 Memory after a PDddS or PUddS command  
CLS  
BDNAME$ = "DEV9"  
eos$ = CHR$(13) + CHR$(10) 'assign the CR-LF  
QNdata$ = SPACE$(6502) "Make room for torque-speed data  
wrt$ = "O" + eos$ 'O+CR-LF command to 29B  
CALL IBFIND(BDNAME$, BD%) "Initialize the GPIB  
CALL IBWRT(BD%, wrt$) 'Output command :  
CALL IBRD(BD%, QNdata$) 'Fetch all memory  
'QNdata$ now contains all Model 5240 test data...
```

What you have is a long data string structured as shown in the following example. To fill in some numbers for our example, let's assume a speed of 1752 RPM and 85.64 oz.in. torque. A block of 3 data samples, anywhere in the string will look like:

.....S01752T85.64S01752T85.64S01725T85.64.....

One simple method to extract individual data points would be to create a FOR-NEXT loop to "walk through" the single variable labeled "QNdata\$." Within the loop, assign two numerical data arrays, one for "Speed" and one for "Torque." Since it is unlikely that all the memory was filled with data, zeros will be outputted where the test stopped. You could omit these by making the array assignment conditional on both torque and speed being greater than zero. This step is not included in the example.

```
DIM Speed(600), Torque(600)  
n = 1 'Initialize array number  
FOR I = 2 TO 6005 STEP 12 'Step a block at a time  
Speed(n) = VAL(MID$(QNdata$, I, 5))  
Torque(n) = VAL(MID$(QNdata$, I + 6, 5))  
n = n + 1  
NEXT
```

PROGRAMMING EXAMPLE FOR "I" COMMAND USE

To apply a torque value to the test motor as rapidly as possible, the Iddd command provides a method to directly address the Q-D/A converter. The I instruction requires that the numerical value used with it be a number from 1 to 4095. In order to relate this to torque, first output a "Qdd.dd" command, made dd.dd equal to the value of torque you want (2.0 is selected in the example), delay a few seconds for the system to respond and

settle, then ask for the contents of the Q-D/A converter with the “X” command. Concatenate the number returned with the I command.

```
'$INCLUDE: 'c:\gpib-pc\qbasic\qbdecl.bas'  
'Routine to use the "I" command  
'TOR$ = Torque value you wish to emulate with the I command  
CLS : eos$ = CHR$(13) + CHR$(10) 'CR-LF  
wrt$ = "Q" + "2.0" + eos$ "2.0" is arbitrary here.  
BDNAME$ = "DEV9" 'primary address = 9  
CALL IBFIND(BDNAME$, BD%)  
CALL IBWRT(BD%, wrt$) 'Loading Q2.0 (2.0 units of torque)  
SLEEP (7) 'Wait 7 seconds to settle down  
wrt$ = "X" + eos$ 'Q-D/A Data request  
CALL IBWRT(BD%, wrt$)  
QDA$ = SPACE$(6) 'always returns 4 digits + CR-LF  
CALL IBRD(BD%, QDA$) 'D/A converter value  
FASTQ$ = "i" + QDA$ '+Idddd  
CALL IBWRT(BD%,FASTQ$) '-this may go anywhere for fast Q loading
```

PROGRAMMING EXAMPLE FOR “Z” COMMAND USE

To apply a value of speed to the test motor as rapidly as possible, the Zdddd command directly addresses the N-D/A converter. The Z instruction requires a numerical value of 1 to 4095. To establish this value relative to the speed you wish to apply, use the Ndddd instruction first. After the speed has settled, output a “Y” data request. The 4-digit value returned may then be concatenated with “Z” for fast speed loading.

Be sure that the *speed range* has been previously established!

```
'$INCLUDE: 'c:\gpib-pc\qbasic\qbdecl.bas'  
'Routine to use the "Z" command  
CLS  
eos$ = CHR$(13) + CHR$(10) 'CR-LF  
wrt$ = "N" + "1750" + eos$  
BDNAME$ = "DEV9" 'primary address = 9  
CALL IBFIND(BDNAME$, BD%)  
CALL IBWRT(BD%, wrt$)  
SLEEP (7) : WRT$ = "Y" + eos$  
CALL IBWRT(BD%, wrt$)  
NDA$ = SPACE$(6)  
FASTN$ = "Z" + nda$  
CALL IBWRT(BD%,FASTN$) 'this may go anywhere for quick N loading.
```

If you have questions regarding any of the above examples, or if you have suggestions regarding software development, please feel free to contact Magtrol Software Engineering at any time.

APPENDIX B: Inertia Correction

INERTIAL EFFECT ON MOTOR TEST DATA

A major advantage of the Magtrol Speed Controlled System is the ability to obtain full (free run to locked rotor) motor performance data by continuous load application with an absorption dynamometer. Data acquisition is fast, resulting in minimal motor I²R losses, and loading characteristics simulate actual end-use applications.

When a motor is accelerating or decelerating, the measured torque is the sum of the true motor torque \pm the inertial torque (stored energy) of the system. Unless inertial torque is excluded, motor performance data will be in error, since the measured torque will vary in proportion to the rate of acceleration/deceleration.

This type of error can produce startling test results. For example, during rapid deceleration, system inertia can produce apparent efficiency greater than 1.0! This may occur as output power is divided by input power without extracting the stored energy in the system. Alluding to perpetual motion causes most technically oriented people to suspect the data.

DATA TIMING FACTOR

Since “inertial effect” is only a factor as speed is changing, and since inertial torque is proportional to the rate of change, inertial value may be expressed as a unit of torque *per* change in RPM *in a given period of time*.

Model 5240 accumulates and outputs test data at fixed intervals of 0.10 second. Therefore, change in RPM occurs over that fixed period, regardless of test rates. It might seem desirable to output data at fixed intervals of speed or torque, perhaps every 100 RPMs or some other figure which is easy to work with. But this would preclude the ability to extract inertial error effects, unless we could somehow accurately measure and rapidly output the elapsed time between every data point. If you must have speed/torque data in even decades, various computer software routines provide fast and accurate curve fitting techniques to do this for you.

PROCEDURE

In order to create a torque Correction Factor (CF), we need:

1. A torque value equal to the inertial torque.
2. The difference in RPM (per 0.1 sec) that created *that* value.

In the following graph example, we have arbitrarily selected a data point on the performance curve. We want to program down by increasing torque load and fetch a group of test points. We have selected the first data point, where speed will be just less than 78% of the Free Run speed. Call this the *dynamic speed value*. Additionally, save one test point before this value and one after. Immediately program Model 5240 (Nddddd) to a speed exactly equal to this “dynamic” value. When the speed has stabilized, fetch this as the *static torque value*.

To calculate CF, first average the speed change *between* 3 test points. Next, calculate the difference in torque between the static speed value and the dynamic speed value. Divide this torque difference by the *average* change in speed. The result is your CF.

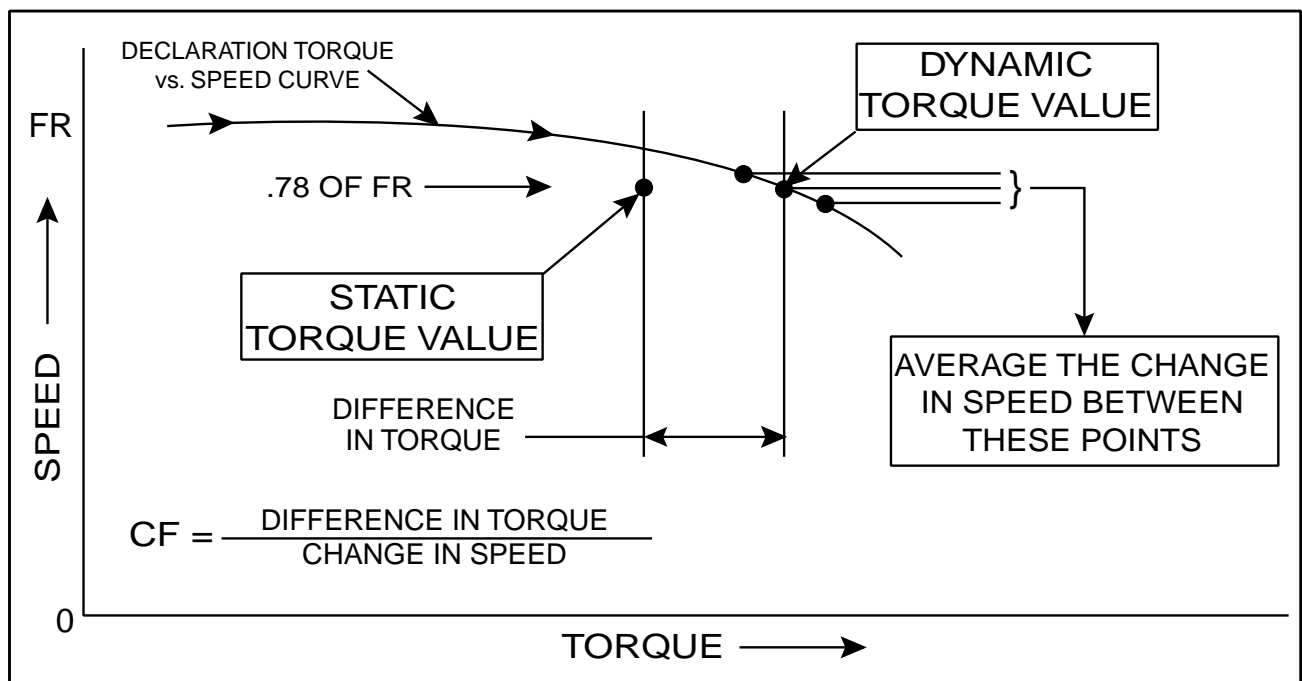

A few key conditions:

- The test point selection of “0.78” is fairly typical for an induction motor. Select this value in an area where the performance curve is fairly linear, and there is a substantial torque change with speed.
- The data must be acquired rapidly, so that motor heating does not degrade performance by adding a false difference between the static and dynamic torque values.
- The input line voltage must be stable for the 1 or 2 seconds needed to perform the test. Torque varies by the square of the change in line voltage. Use a regulated power source.

INERTIA CANCELLATION PROGRAM

The following steps outline a computer program, in Quick Basic, to control Model 5240 for the acquisition of a “CF” value. Initialization:

```

$INCLUDE: 'c:\gpiib-pc\qbasic\qbdecl.bas'
'fr = free run speed. You must assign this value.
BDNAME$ = "DEV9" 'Primary addr = default code 9.
CALL IBFIND(BDNAME$, BD%) 'Initialize the GPIB.
eos$ = CHR$(13) + CHR$(10) 'CR-LF termination char's.

```

PROGRAMMING STEPS

1. With the system up and running, command a PD99 instruction to Program Down to 78% of the free run speed:

```
wrt$ = "PD99" + eos$ 'Program Down at a fast rate.  
      CALL IBWRT(BDNAME$, wrt$) 'Send it to Model 5240  
rd$ = SPACE$(15) "Assign room for the data + CR-LF"
```

2. Collect data in an array. (Single data point = SddddTddd.dL.)

```
X = 0 'X is our array # = selected speed point.  
DO: X = X + 1  
    CALL IBRD(BD%, rd$) 'rd$ is the data from Model 5240  
    ND(X) = VAL(MID$(rd$, 2, 5)) 'SPEED  
    QD(X) = VAL(MID$(rd$, 8, 5)) 'TORQUE  
LOOP UNTIL ND(X) < .78*fr 'fr = free run RPM assigned.
```

3. Set up the static value as an N instruction. Model 5240 will apply it when the current PD99 instruction terminates. NOTE: An Ndddd will not override an *in process* PDdd instruction.

```
wrt$ = "N" + STR$(ND(X)) + eos$ 'Static speed value.  
CALL IBWRT(BD%, wrt$)
```

4. Save the next N-Q test point < the .78 FR value:

```
Y = X 'Keep X intact, change array # to Y.  
DO: Y = Y + 1  
    CALL IBRD(BD%, rd$)  
    ND(Y) = VAL(MID$(rd$, 2, 5))  
    QD(Y) = VAL(MID$(rd$, 8, 5))  
LOOP UNTIL Y = X + 1
```

5. Send a "PR" instruction to stop further loading. The system will revert automatically to the "N" value installed by Step 3 above.

```
wrt$ = "PR" + eos$ 'Stop PDdd, revert to static point  
CALL IBWRT(BD%, wrt$)
```

6. Calculate the average difference in speed between the test points. Call it (avgdN).

```
avgdN = (ND(X-1) - ND(X)) + (ND(X) - (ND(X + 1)))  
avgdN - avgdN/2
```

-
7. Now wait for the static speed to be equal to the dynamic speed value previously obtained. Hold in a loop until 3 speed readings agree - just to be sure.

```
samples = 0 'Null it.  
DO: CALL IBRD(BD%, rd$)  
    speed = VAL(MID$(rd$, 2, 5))  
    torque = VAL(MID$(rd$, 8, 5))  
    IF speed = ND(X) THEN samples = samples + 1  
LOOP UNTIL samples = 2
```

8. Return the motor to free run speed.

```
wrt$ = "N" = eos$  
CALL IBWRT(BD%,wrt$)
```

9. Determine the Correction Factor CF.

```
CF = (QD(X) - torque)/avgdN
```

CORRECTING TEST RUN PERFORMANCE DATA

The following program fragment shows one method to correct data, using a previously obtained CF. You have run a complete motor test by PDdd, PUdd or both, acquiring the "SdddddTdd.ddL" type data in an array.

AN = Array counter (number)

Dta\$(AN) = Your test run data, a string variable array.

To correct each torque value in the array of test data, you must first subtract each speed test point from the preceding speed test point value. Call this a numerical variable dN. This number yields the change of speed occurring in the 0.1 second period for that data point. It will be a signed value, positive if the motor is decelerating, negative if accelerating.

Next, multiply dN by the CF. We will call the (signed) product CFdN. This is equal to the inertial torque portion of the torque value for that respective data point. Algebraically sum this with the (test point) torque value, and place the result in a numerical array, Ttor(AN).

```
FOR I = 2 TO AN -1 'Start with the 2nd value!  
    dN = VAL(MID$(dta$(I-1), 2,5)) - VAL(MID$(dta$(I), 2, 5))  
    CFdN = CF * dN  
    Ttor(I) = VAL(MID$(Dta$(I), 8, 5)) - CFdN 'torque +/- inertia.  
NEXT
```

We still have the original test data unchanged. The new data array "Ttor(AN)" contains complete performance curve torque data, with the effects of inertia removed.

If you have any questions regarding any of the above, please contact Magtrol Customer Service, Model 5240 software.

APPENDIX C: Drawings

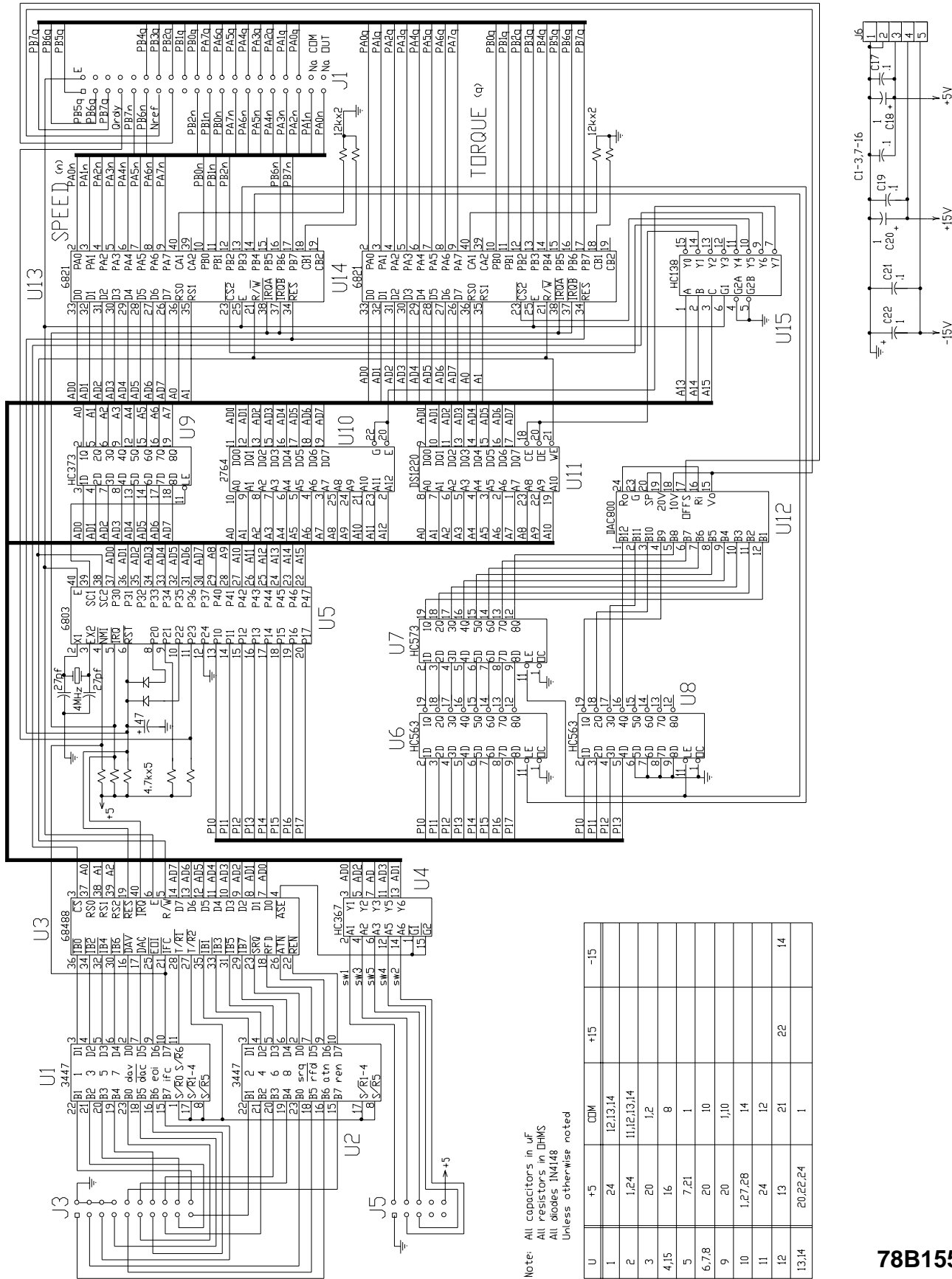

78B156

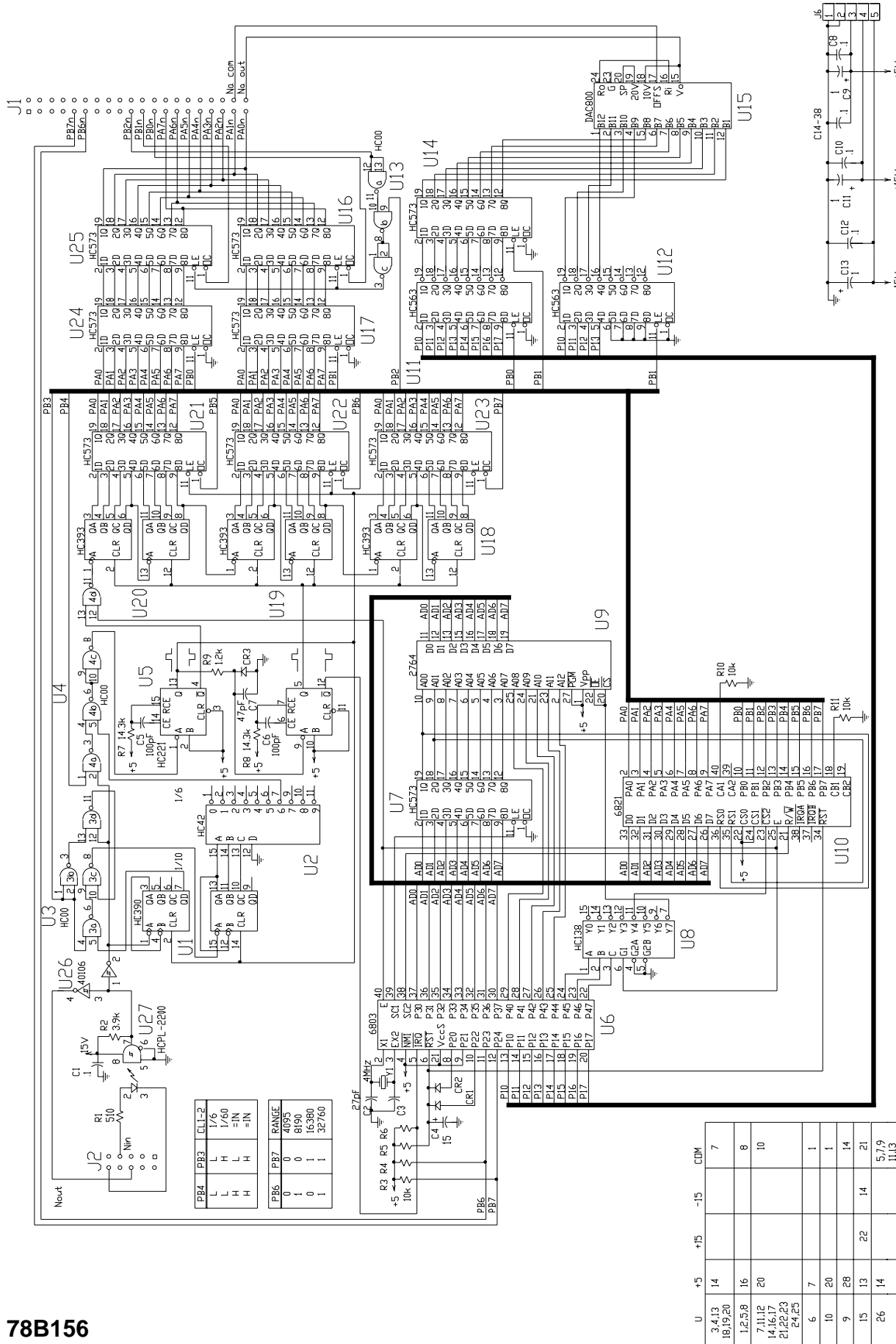

Note: All resistors in Ω M Ω
 All capacitors in μ F
 All diodes 1N4148
 Unless otherwise noted

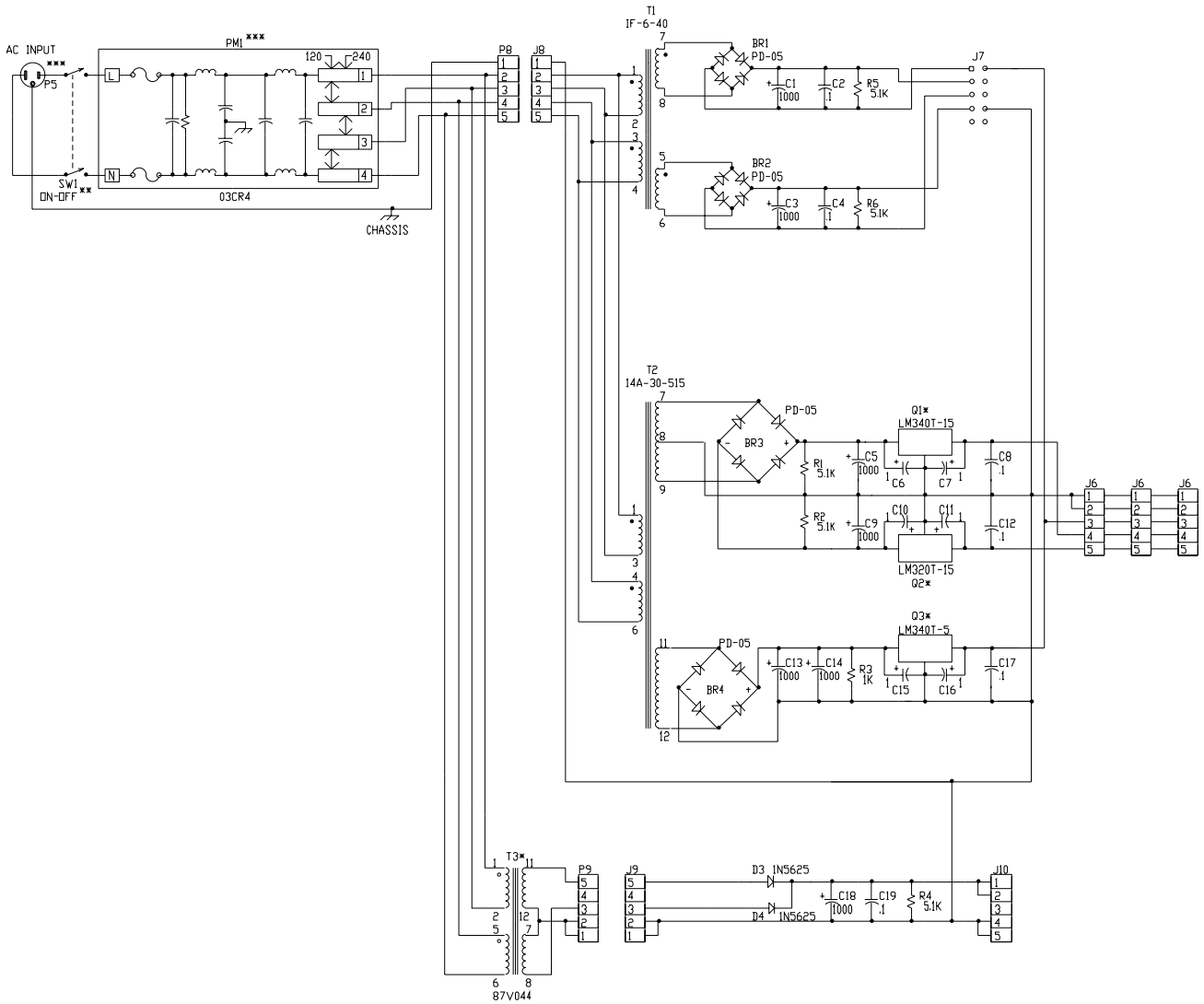

* CHASSIS MOUNT
 ** FRONT PANEL MOUNT
 *** REAR PANEL MOUNT

78B157

78B159

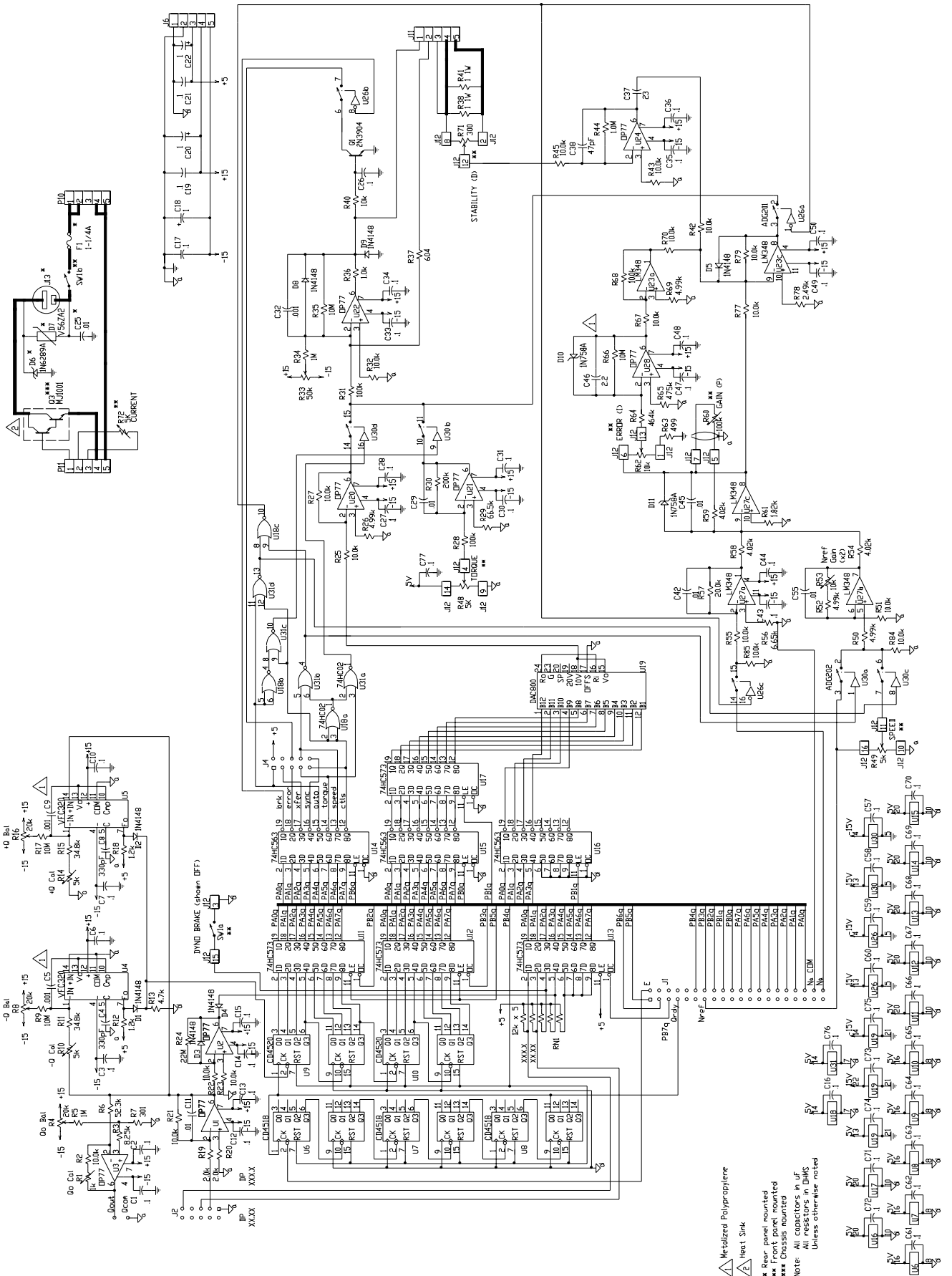

Magtrol Limited Warranty

Magtrol, Inc. warrants its products to be free from defects in material and workmanship under normal use and service for a period of one (1) year from the date of shipment. Software is warranted to operate in accordance with its programmed instructions on appropriate Magtrol instruments. This warranty extends only to the original purchaser and shall not apply to fuses, computer media, or any other product which, in Magtrol's sole opinion, has been subject to misuse, alteration, abuse or abnormal conditions of operation or shipping.

Magtrol's obligation under this warranty is limited to repair or replacement of a product which is returned to the factory within the warranty period and is determined, upon examination by Magtrol, to be defective. If Magtrol determines that the defect or malfunction has been caused by misuse, alteration, abuse or abnormal conditions of operation or shipping, Magtrol will repair the product and bill the purchaser for the reasonable cost of repair. If the product is not covered by this warranty, Magtrol will, if requested by purchaser, submit an estimate of the repair costs before work is started.

To obtain repair service under this warranty, purchaser must forward the product (transportation prepaid) and a description of the malfunction to the factory. The instrument shall be repaired at the factory and returned to purchaser, transportation prepaid. **MAGTROL ASSUMES NO RISK FOR IN-TRANSIT DAMAGE.**

THE FOREGOING WARRANTY IS PURCHASER'S SOLE AND EXCLUSIVE REMEDY AND IS IN LIEU OF ALL OTHER WARRANTIES, EXPRESSED OR IMPLIED, INCLUDING BUT NOT LIMITED TO ANY IMPLIED WARRANTY OF MERCHANTABILITY, OR FITNESS FOR ANY PARTICULAR PURPOSE OR USE. MAGTROL SHALL NOT BE LIABLE FOR ANY SPECIAL, INDIRECT, INCIDENTAL, OR CONSEQUENTIAL DAMAGES OR LOSS WHETHER IN CONTRACT, TORT, OR OTHERWISE.

CLAIMS

Immediately upon arrival, purchaser shall check the packing container against the enclosed packing list and shall, within thirty (30) days of arrival, give Magtrol notice of shortages or any nonconformity with the terms of the order. If purchaser fails to give notice, the delivery shall be deemed to conform with the terms of the order.

The purchaser assumes all risk of loss or damage to products upon delivery by Magtrol to the carrier. If a product is damaged in transit, **PURCHASER MUST FILE ALL CLAIMS FOR DAMAGE WITH THE CARRIER** to obtain compensation. Upon request by purchaser, Magtrol will submit an estimate of the cost to repair shipment damage.

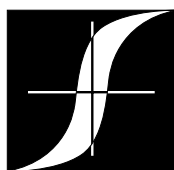

MAGTROL

70 Gardenville Parkway ♦ Buffalo, New York 14224
Phone: (716) 668-5555 ♦ (800) 828-7844 Fax: (716) 668-8705

www.magtrol.com