

# INSTRUCTION MANUAL

MERCURY SLIP – RINGLESS  
TRANSMITTER

4 – MTA / T

P/N 655.001 E

## REVISION RECORD SHEET

Issue	Date	Change, issued by	Description		
1 2 3	Oct 82 Feb 88 Mar 89	Po/pb Eg/ew Rr/ew	Original issue Text has been added into computer Deleted index mark 'M' in page 3		
			Department	Date	Signature
Approved by			Technical Documentation	22.3.89	<i>N. Feun</i>

# TABLE OF CONTENTS

## PROSPECTUS

1.	<u>GENERAL</u>	4
2.	<u>OPERATING PRINCIPLE</u>	4
3.	<u>MECHANICAL MOUNTING</u>	5
3.1.	Sectional view of a mercury transmission cell	6
3.2.	Schematic of mercury transmitter 4-MTA/T	6
4.	<u>ELECTRICAL MOUNTING</u>	7
5.	<u>MAINTENANCE</u>	8
6.	<u>MEASUREMENTS</u>	9
6.1.	Measurements with strain gauges	9
6.2.	Measurements with thermo elements	9
7.	<u>MOUNTING OF THE PULSE TRANSDUCER JP 1412</u>	10
8.	<u>APPLICATION EXAMPLE</u>	10
9.	<u>TECHNICAL SPECIFICATIONS</u>	11
9.1.	Mechanical properties	11
9.2.	Electrical properties	12
9.3.	Pulse transducer JP 1412	12

## ANNEX:

Slip-ringless rotary transmitter                      VZ 940 a



# MERCURY SLIPRINGLESS TRANSMITTERS QUECKSILBER-DREHUBERTRAGER TRANSMETTEURS ROTATIFS A MERCURE

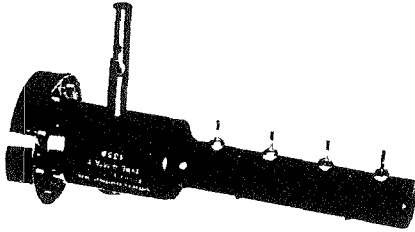

Type 4-MTA/T  
Ref. No. 6410

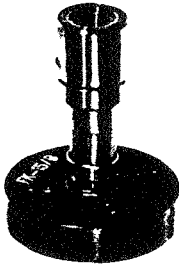

Type FK-15/B  
Ref. No. 6411



Type MT-8/A  
Ref. No. 6414

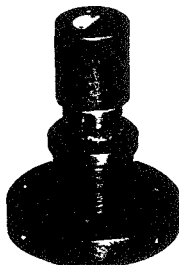

Type MT-K/A  
Ref. No. 6416

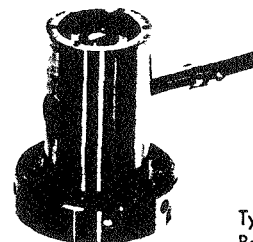

Type MT-A/A  
Ref. No. 6415

## GENERAL DESCRIPTION AND APPLICATION

The mercury rotary slipringless transmitters 4-MTA/T and MT-8/A (Rohrbach system) are four and eight channel systems for the transmission of electrical measuring signals from rotating test specimens to stationary measuring instruments. They are exceptionally well suited for the transmission of electrical signals from thermocouples, strain gages, oscillation pick-ups, accelerometers, geophones, etc. They can be used to transmit excitation power to these devices in addition to transmitting the measuring potentials from them. The transmitters have been particularly satisfactory in the measurement of temperatures and of mechanical values on rotation parts of turbines, jet engines, turbo-compressors, propellers, motors, superchargers, machine - tools and other machines, as well as for running tests on all types of road and rail vehicles. The speed range of up to 40'000 R.P.M. permits read-outs, such as strain measurements by strain gages heretofore considered impossible, on specimens at very high rotational speeds. The mercury transmitters succeed in eliminating almost completely the numerous disadvantages of the usual solid contact transmitters, e.g. the variations in insulation and contact resistances and parasitic thermal E.M.F. They are, therefore, superior to all rotary transmitters using rings, brushes, wire loops, mercury dipping cups and similar devices.

Type 4-MTA/T of 4 mercury transmission cells, a pulse wheel, a housing with support for connection of a pulse pick-up. For medium and high speed operations, it is recommended to use the flexible coupling, Type FK-15/B for vibration damping.

Type MT-8/A consists of 8 mercury transmission cells. This device can be plugged into the drive flange Type MT-A/A in which a pulse wheel and support for connection of a pulse pick-up is built-in. For medium and high speed operations, the same flexible coupling as recommended for transmitter 4-MTA/T should be used.

If the pulse wheel is not required, the transmitter Type MT-8/A may be plugged direct to the special flexible coupling Type MT-K/A.



# MERCURY SLIPRINGLESS TRANSMITTERS QUECKSILBER-DREHÜBERTRAGER TRANSMETTEURS ROTATIFS A MERCURE

## TECHNICAL SPECIFICATION

TYPE	4-MTA/T	MT-8/A
Number of channel	4	8
Speed ranges	long term operation 0 - 20'000 RPM short term operation 0 - 40'000 RPM	
Temperature range	- 25 to + 60° C	
Thermal EMF	2 microvolt typical with two cells connected in series and at speeds 0 - 20'000 R.P.M. corresponding to a possible error of 0,05% for a constantan-chromium nickel thermocouple, at a temperature difference of 600°C.	
Contact resistance	Max. 0,2 milli-ohms instantaneous variation for 2 cells in series at 0 - 5000 R.P.M. (This corresponds to an apparent strain of $\pm 4,2$ micro-strain for 2 strain gages of 120 ohms each and a gage factor of 2,0). At 0-20'000 R.P.M. max. 0,5 milli-ohms.	
Load wire resistance	0,03 - 0,06 ohms depending on the length of the lead from each individual cell.	
Insulation resistance	More than 10 <sup>10</sup> ohms for two adjacent cells.	
Total noise	Typical 25 microvolts (max. 50 microvolts) with two cells in series at speeds 0 - 20'000 R.P.M.	
Load current	Max. 0,5 amps per cell.	
Load voltage	60 VAC or DC between two cells or between cell and transmitter housing.	
Connections	Soldering terminals on rotor and stator.	
Accessories	Flexible coupling, type FK-15/B  Magnet pulse pick-up with cable connector, Pair of bearing brackets	Drive flange with built-in pulse-wheel, type MT-A/A or Flexible coupling, type MT-K/A type JP/1412 type G 247-27
Weight	4-MTA/T = 780 gr FK-15/B = 320 gr	MT-8/A = 530 gr. MT-A/A = 680 gr. MT-K/A = 100 gr

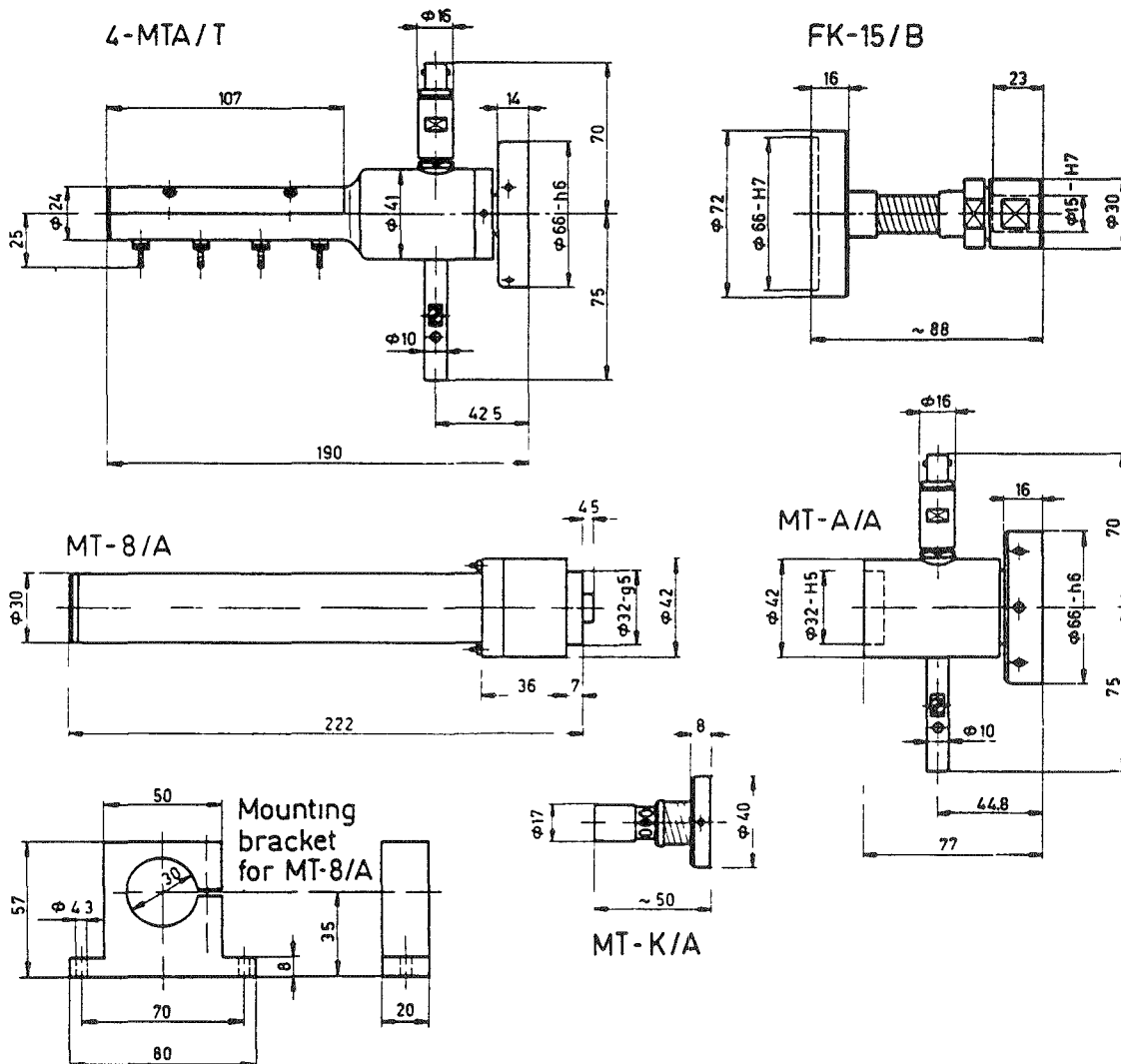

1. GENERAL

The mercury rotary slip-ringless transmitters 4-MTA/T, manufactured by VIBRO-METER, find an application in the transmission of electrical measuring signals from rotating test specimens.

The mercury transmission eliminates the numerous disadvantages found with normal contact systems: transmission and insulation resistance and thermal noise E.M.F.

These transmitters are superior to all rotary transmitters using rings, brushes, wire loops, mercury dipping cups and similar devices. They can transmit both DC and AC signals.

They are strongly built mechanically and electrically.

They can be used in research and development laboratories where practical measurements are effected on rotating test items.

2. OPERATING PRINCIPLE

See drawing and sectional view of the mercury transmission cell. It works with a very small mercury droplet, into which a platinum-iridium tube of .080" diameter dips as a contact.

As the speed at the contact surface is thereby substantially reduced, the E.M.F. due to metal heating and the variations in insulation resistance due to mercury vapour are avoided.

The miniaturization of the transmission cell offers yet further advantages:

- The small amount of mercury 3.5 g eliminates any health hazards.
- The relatively expensive analytical mercury used offers optimum electrical transmission properties.
- The inside of the mercury cup and the contact tube are lined with platinum-iridium keeping the mercury pure, thus assuring excellent transmission contact.
- Due to its surface tension, the mercury droplet encloses the contact tube so intimately, that neither high interference accelerations nor vertical mounting of the transmitter affect the contact quality.

Special attention was given to the sealing of the mercury cups, which remain tight even at axial accelerations of 50 g.

The mercury transmission cells are mounted in the housing fully insulated. Their contact tubes are interconnected by flexible, electrically insulating couplings.

The mounting flange of the main housing has built-in solder terminals which are accessible from two sides. It is thus possible to run the rotating signal leads to the transducer along either the outside or the inside of a hollow shaft.

3. MECHANICAL MOUNTING (See next page for para 3.1 and 3.2)

A flexible coupling, type FK-15/B. is used between the transducer and the measuring object. This is to protect the cell from vibrations, and therefore to extend the life time.

Four M5 'Allan' screws (4) or four M4 screws (3) are used to fix the transmitter either by the fixing shaft (1) or on the diameter (N) by a mounting support.

It is recommended to line up the transducer with the shaft of the measuring object, to avoid unnecessary strain on bearings or coupling.

### 3.1. SECTIONAL VIEW OF A MERCURY TRANSMISSION CELL

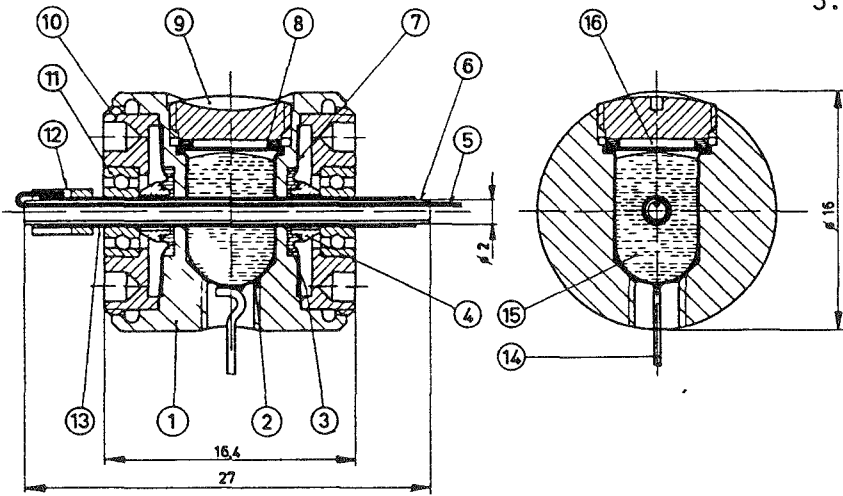

- 1 Stainless steel housing
- 2 Platinum-iridium cup lining
- 3 Felt packing
- 4 Sapphire sealing
- 5 Teflon insulated copper lead wire
- 6 Silicone filling medium
- 7 Diaphragm
8. Platinum-iridium sealing disc
- 9 Locking screw
10. Threaded ring
- 11 Lubricated-for-life miniature ball bearing
- 12 Solder ring
- 13 Platinum-iridium contact tube
- 14 Platinum connecting wire
- 15 Analytic (high purity) mercury filling
16. Rubber washer

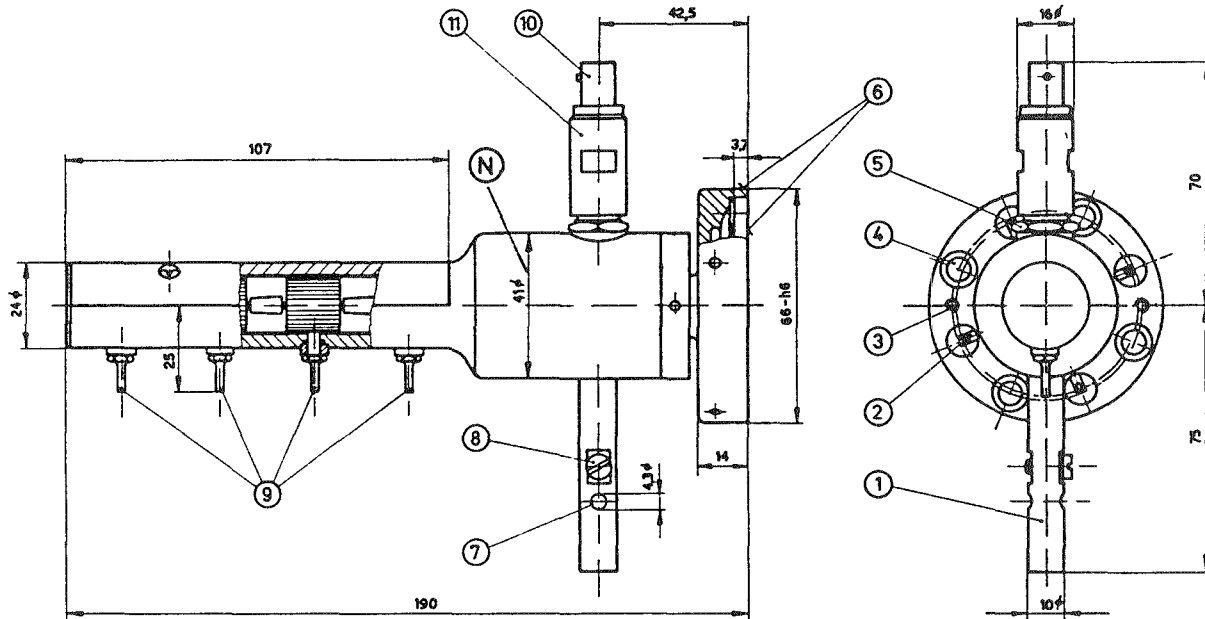

### 3.2. SCHEMATIC OF MERCURY TRANSMITTER 4-MTA/T

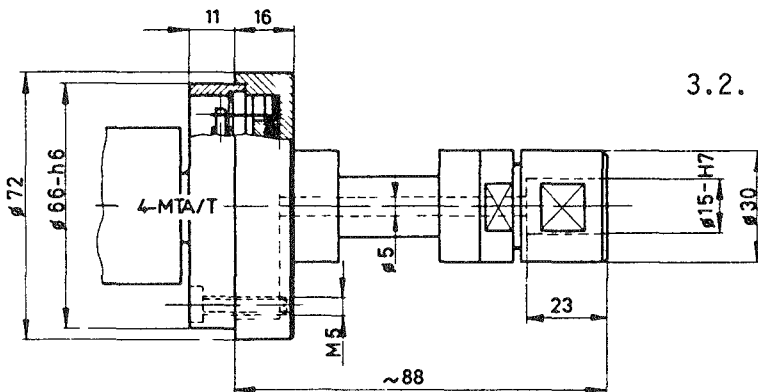

1. Locking lever
2. Rotating solder terminals
3. 4 mounting holes // 8—32 on 2 1/2" dia B C
4. 4 mounting holes for // 8—32 socket head cap screws on 2 1/2" B.C.
5. Lock nut for pulse pickup JP / 1412
6. Mounting base, plain-ground
7. Socket for ground jack
- 8 Grounding screw
- 9 Stationary solder terminals
10. BNC type jack EF 031—50 for the pulse pickup
11. Screw-in connector assembly JP/1412 cable

Flexible coupling FK-15/B



4. ELECTRICAL MOUNTING

The measuring element wires are soldered on to the flange. Take care that no lumps of solder are left, which could unbalance the system when rotating at high speeds.

I M P O R T A N T :

Only non-corrosive solder is to be used. The use of corrosive solvents or flux should be absolutely avoided, as these would greatly influence the leakage current and insulation resistance.

To suppress interferences, the housing can be earthed. The earth cable is attached to the fixing shaft (1) by means of the screw (8).

The electrical connections on the rotating part of the measuring object must be fixed securely, otherwise cable vibrations could produce breaks in the wires or solder joints.

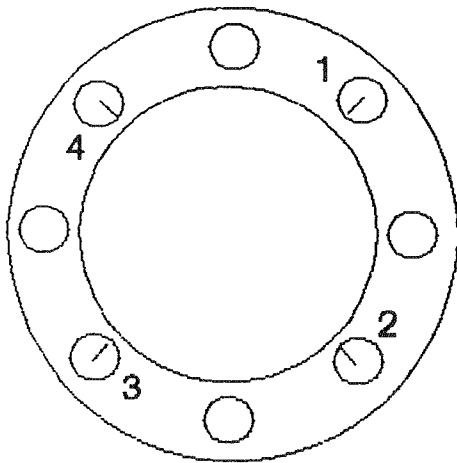

The numbers on the rotating part correspond to the numbering of the cells (The outside cell is number 1).

5. MAINTENANCE

The ball bearings are lubricated for life and do not require any maintenance, similarly the miniature ball bearings of the mercury cells and the coupling flange.

It is recommended to send the transmitter to the factory for checking the bearings after two or three years if it is operated at very high speed.

We strongly advise our customers against doing the lubrication themselves; it must be done in a dust-free atmosphere, in order not to reduce the bearing life time.

If it happens that after a certain operating time spontaneous changes in the dynamic transmission resistance cause inadmissible interference, it can be concluded that the mercury cells have become dirty, due mainly to mercury oxide.

In order to carry out a cleaning without any risk, it is recommended to send the transmitter back to the factory.

## 6. MEASUREMENTS

### 6.1. Measurements with strain gauges

DC or carrier frequency strain gauge measuring bridges allow carrying out static or static-dynamic measurements.

The following points should be noted (see fig. page 3):

- With active strain gauges, it is necessary to use wire lengths as short as possible to the solder connections (2). The temperature influence of the connecting wires is then kept minimal.
- By using strain gauges with high resistance, it is possible to reduce any temperature influence.
- For a strain gauge half-bridge, the 2 external points should be wired to 2 adjacent solder connections and the mid-point to any one of the other solder connections.
- Temperature influence of the connecting wires is eliminated when a strain gauge full bridge is used.

### 6.2. Measurements with thermo elements

According to the specifications para. 9, the transmitter produces a very small thermal EMF at very high speeds. It is to be noted in precise temperature measurements that the solder connections on the fixed part of the housing and on the flange represent also thermo elements.

For precise measurements, it is necessary that the rotating object does not warm up the transmitter. It is also to be noted that rotating solder connections on the flange and the solder connections on the housing should be at the same temperature.

An intermediate teflon disc can be used in order to avoid any possible passage of heat via the coupling flange.

7. MOUNTING OF THE PULSE TRANSDUCER JP 1412

In order to obtain a correct mounting of the transducer and the right gap between the head of the transducer and the pulse wheel, follow the instructions given below:

- Remove the screw cap on the head of the transducer. The teeth of the pulse wheel can be seen.
- The taller reference tooth of the pulse wheel must be opposite the opening.
- Turn the flange by hand to obtain the right position.
- Unscrew the transducer locknut.
- Screw the transducer in until it just touches the tooth.
- The unscrew one turn. The thread is of 0.5 mm pitch. A gap of 0.5 mm is thus obtained between the head of the transducer and the reference tooth.
- Tighten the transducer locknut again.
- Turn the flange by hand and check that the transducer does not touch the tooth.

8. APPLICATION EXAMPLE

On the last page, an example of the numerous applications of the pulse transducer JP 1412 is given with the associated electronics of the PERMODULE System.

9. TECHNICAL SPECIFICATIONS

9.1. Mechanical properties

Principle	: transmitters with 4 built-in mercury transmission cells.
Speed ranges rpm	: 0 - 20'000 long term operation 0 - 40'000 short term operation
Temperature range	: -25° C to 60° C
Bearing lubrication	: carried out by the manufacturer. Periodic revision every 2 - 3 years.
Acceleration	: max. 20 g (short term).
Torque	: $6 \cdot 10^{-3}$ Nm
Moment of inertia	: $4 \cdot 10^{-3}$ kgm <sup>2</sup>
Cell filling	: approx. 3.5 g of pure analytical mercury.
Pulse wheel	: 6 teeth, one of which is 20 % higher as a reference mark.
Transducer thread	: M14 x 0.5
Weight	: 780 g.
Flexible coupling	: FK - 15/B : 320 g.

9.2. Electrical properties

- Thermal EMF : 2 micro-volts typical with 2 cells connected in series and at speeds 0 - 20'000 rpm corresponding to a possible error of 0.05 ‰ for a constant-chromium nickel thermocouple, at a temperature difference of 1'100° F (600° C).
- Contact resistance : max. 0.2 mΩ instantaneous variation for two cell cells in series at 0-5'000 rpm (this corresponds to an apparent strain of ±4.2 micro-strain for 2 strain gauges of 120 Ω each and a gauge factor 2.0).  
At 0 - 20'000 rpm: max. 0.5 mΩ.
- Load wire resistance : 0.03 - 0.06 Ω depending on the length of the lead from each individual cell.
- Insulation resistance : >10<sup>10</sup> Ω for two adjacent cells.
- Total noise : typical 25 micro-volts (max. 50 micro-volts) with two cells in series at speeds 0 - 20'000 rpm.
- Load current : max. 0.5 amps per cell.
- Load voltage : 60 V AC or DC between two cells or between cell and transmitter housing.
- Contact surfaces : mercury to platinum-iridium.
- Connections : soldering terminals on rotor and stator.

9.3. Pulse transducer JP-1412

- Gap : 0.5 mm between the transducer head and the wheel tooth.
- Output : 6 approx. sine wave oscillations per revolution, one of which of approximately 20 % larger amplitude, used for the indication of the angle of rotation.  
1.2 V peak-to-peak per 1'000 rpm with a load resistance of 100 kΩ or more.  
Linearity better than ±1.5 %. Phase shift smaller than 0.5° at 10'000 rpm.
- Internal resistance :        0 - 10'000 rpm ≤1.3 kΩ  
                 10'000 - 20'000 rpm 1.3 - 2 kΩ  
                 40'000 rpm            3 kΩ

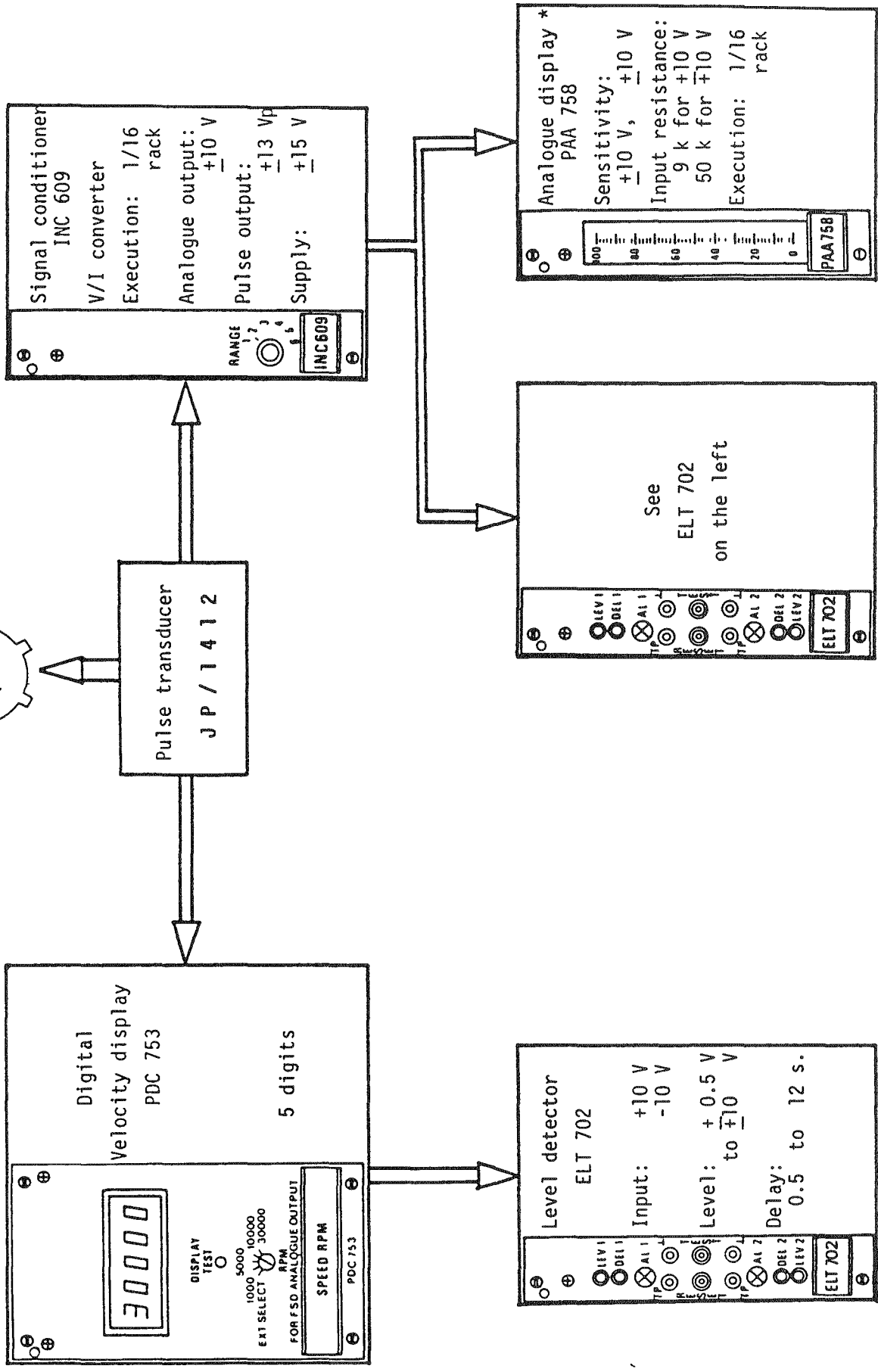
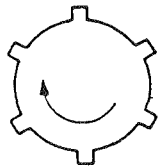

\* other executions in option

