

vibro-meter

Type	MT-8/A	Version	
Subject	EIGHT - CHANNEL - MERCURY SLIPRINGLESS - TRANSMITTER		
INSTRUCTION MANUAL			

P/N		E
-----	--	---

	DEPARTMENT	SIGNATURE
Prepared by	V I P	Eg/ew
Checked by	V I P	
Approved by		
Approved by		

REVISION RECORD SHEET

Issue	Date	Changed, issued by	Page	Paragraph, figure	Changes, remarks
1	OCT. 85	M.Egger	ALL	ALL	ORIGINAL ISSUE
2	FEB. 88	Eg/ew			ORIGINAL IN COMPUTER

TABLE OF CONTENTS

P A G E

1.	8-CHANNEL MERCURY ROTARY SLIPRINGLESS TRANSMITTER	1
1.1.	Specifications	1
1.1.1.	Mechanical properties of MT-8/A	1
1.1.2.	Electrical properties	2
1.2.	General	2
1.3.	Operating principle	3
1.4.	Mounting	4
1.4.1.	Mechanical installation	4
1.4.2.	Electrical connections	4
1.5.	Maintenance	7
1.6.	Measurements	8
1.6.1.	Measurements with strain gauge	8
1.6.2.	Measurements with thermo elements	8
2.	PULSE TRANSDUCER JP-1412	9
2.1.	Specifications	9
2.2.	Mounting	10

ANNEX:

Slipringless rotary transmitter MT-8/A	VZ 558c VZ 940a VZ 557c
Slipringless rotary transmitter MT-8/A with flange MT-A/A	VZ 556/1a
Flexible coupling MT-K/A	VZ 571
Flexible coupling FK-15/B	VZ 579
Support G247-27	VZ 572 a
Application with transducer	

1. EIGHT-CHANNEL MERCURY ROTARY SLIPRINGLESS TRANSMITTER MT-8/A

1.1. Specifications

1.1.1. Mechanical properties of MT-8/A

Principle : transmitter with 8 built-in mercury transmission cells

Speed ranges rpm : 0 - 20'000 rpm long term operation
0 - 40'000 rpm short term operation

Temperature range : -25° C to +60° C

Bearing lubrication : carried out by the manufacturer.
periodical revision every 2 - 3 years.

Acceleration : max. 20 g (short term)

Cell filling : approx. 3.5 g of pure analytical mercury

Weight : 530 g

Coupling flange : Variation 1
MT-A/8 with transducer thread M14 x 0.5
Weight: 680 g
connected with FK-15/B flexible coupling
Weight: 320 g

Variation 2

MT-K/A flexible coupling
Weight: 100 g

1.1.2. Electrical properties

- Thermal EMF : 2 μ V typical with two cells connected in series and at speed 0 - 20'000 rpm.
- Contact resistance : max. 0.2 m Ω instantaneous variation for two cells in series at 0 - 5'000 rpm.
At 0 - 20'000 rpm \rightarrow max. 0.5 m Ω .
- Load wire resistance : 0.03 - 0.06 Ω , depending on the length of the lead from each individual cell.
- Insulation resistance: $>10^{10}$ Ω for two adjacent cells.
- Total noise : typical 25 μ V (max. 50 μ V) with 2 cells in series at speed 0 - 20'000 rpm.
- Load current : max. 0.5 amps per cell.
- Load voltage : 60 VDC or AC between 2 cells or between cell and transmitter housing.
- Contact surfaces : mercury to platinum-iridium.
- Connections : soldering terminals on rotor and stator.

1.2. General

The mercury rotary slip-ringless transmitter MT-8/A finds its application in the transmission of electrical measuring signals from rotating test specimens.

The mercury transmission eliminates the numerous disadvantages found with normal contact systems: transmission and insulation resistance and thermal noise E.M.F.

This transmitter is superior to all rotary transmitters using rings, brushes, wire loops, mercury dipping cups and similar devices. It can transmit both DC and AC signals. It is strongly built mechanically and electrically.

It can be used in research and development laboratories where practical measurements are effected on rotating test items.

1.3. Operating principle

See drawing and sectional view of the mercury transmission cell (annex VZ 558c).

It works with a very small mercury droplet, into which a platinum-iridium tube of .080" diameter dips as a contact. As the speed at the contact surface is thereby substantially reduced, the E.M.F. due to metal heating and the variations in insulation resistance due to mercury vapour are avoided.

The miniaturization of the transmission cell offers yet further advantages:

- the small amount of mercury 3.5 g eliminates any health hazards,
- the relatively expensive analytical mercury used offers optimum electrical transmission properties,
- the inside of the mercury cup and the contact tube are lined with platinum-iridium keeping the mercury pure, thus assuring excellent transmission contact,
- Due to its surface tension, the mercury droplet encloses the contact tube so intimately, that neither high interference accelerations nor vertical mounting of the transmitter affect the contact quality.

Special attention was given to the sealing of the mercury cups, which remain tight even at very high accelerations.

The mercury transmission cells are mounted in the housing fully insulated. Their contact tubes are interconnected by flexible, electrically insulating couplings.

1.4. Mounting

1.4.1. Mechanical installation

A flexible coupling is used between the transducer and the measuring object, in order to protect the cell from vibrations.

Two kinds of couplings are possible:

- When the speed is not measured i.e. the MT-A/A is not used, a flexible coupling MT-K/A is chosen (see annex VZ 557c).
- In case of a speed measurement with the MT-A/A and the transducer JP 1412, the flexible coupling FK-15/B is chosen (see annex VZ 556/1).

The transducer is mounted on a mounting support G247-27 (see annex VZ 572a) which protects the mercury cell against vibrations. If MT-A/A is used it is necessary to fix this one either with the mounting support G247-27 too or on the support, item Nr. 4 on drawing VZ 556/1Q (see annex).

It is recommended to line up the transducer with the shaft of the measuring object, to avoid unnecessary strain on bearings or coupling.

1.4.2. Electrical connections

The measuring element wires are soldered either to the flange MT-A/A or the flexible coupling MT-K/A (see annex VZ 571).

Take care that no lumps of solder are left which could unbalance the system when rotating at high speed.

IMPORTANT:

Only non-corrosive solder is to be used. The use of corrosive solvents or flux should be absolutely avoided, as these would greatly influence the leakage current and insulation resistance.

To suppress interference, the housing has to be earthed (e.g. by the fixing shaft of the flange).

The electrical connections on the rotating part must be fixed carefully in order to avoid broken wires and broken solder joints.

The colour code of the transmitter connection corresponds with those of the flange.

When using the flexible coupling MT-K/A the connections on the corresponding connector are given by the following table and figures.

SOLDERING POINTS MT-8/A			FLANGE	MT-A/A	FLEXIBLE COUPLING CONNECTOR MT-K/A
Nr.	Colour	Cell	Colour	Nr.	Nr.
1	black	1	black	5	5
2	red	2	red	6	6
3	white	3	white	7	7
4	yellow	4	yellow	8	8
5	green	5	green	1	1
6	blue	6	blue	2	2
7	violet	7	violet	3	3
8	grey	8	grey	4	4

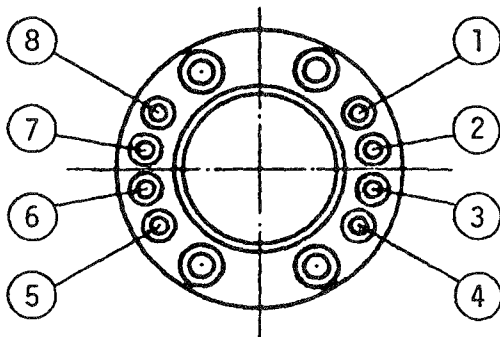

Connections MT-8/A

All connectors are soldered for an 8-cell transducer.

The connector is wired as follows:

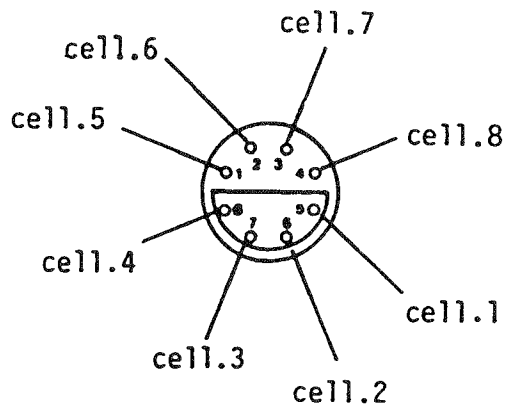

Front view

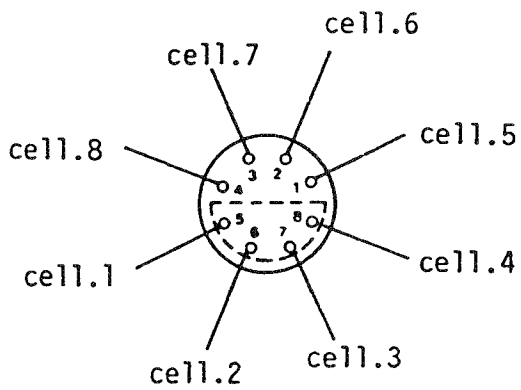

Rear view

The colour code corresponds to the transducer connections.

1.5. Maintenance

The ball bearings are lubricated for life and do not require any maintenance, similarly the miniature ball bearings of the mercury cells and the coupling flange.

It is recommended to send the transmitter to the factory for checking the bearings after 2 or 3 years if it is operated at very high speed.

We strongly advise our customers against doing the lubrication themselves; it must be done in a dust-free atmosphere, in order not to reduce the bearing life time.

If it happens that after a certain operating time spontaneous changes in the dynamic transmission resistance cause inadmissible interference, it can be concluded that the mercury cells have become dirty, due mainly to mercury oxide.

In order to carry out a cleaning without any risk, it is recommended to send the transmitter back to the factory.

1.6. Measurements

1.6.1. Measurements with strain gauge

DC or carrier frequency strain gauge measuring bridges allow carrying out static or static-dynamic measurements.

The following points should be noted (see drawing VZ 557c):

- With active strain gauges, it is necessary to use wire lengths as short as possible to the solder connections. The temperature influence of the connecting wires is then kept minimal.
- By using strain gauges with high resistance, it is possible to reduce any temperature influence.
- For a strain gauge half bridge, the 2 external points should be wired to 2 adjacent solder connections and the mid-point to any one of the other solder connections.
- Temperature influence of the connecting wires is eliminated when a strain gauge full bridge is used.

1.6.2. Measurements with thermo elements

According to the specifications para. 1.1. the transmitter produces a very small thermal EMF at very high speeds. It is to be noted in precise temperature measurements that the solder connections on the fixed part of the housing and on the flange represent also thermo elements.

For precise measurements, it is necessary that the rotating object does not warm up the transmitter. It is also to be noted that rotating solder connections on the flange MT-A/A or the flexible-coupling MT-K/A should be at the temperature of the fixed connections.

An intermediate teflon disc can be used in order to avoid any possible passage of heat via the coupling flange.

2. PULSE TRANSDUCER JP-1412

2.1. Specifications

Gap : 0.5 mm between the transducer head and the wheel tooth

Output : 6 approx. sine wave oscillations per revolution, one of which of approximately 20 % larger amplitude, is used for the indication of the angle of rotation.

1.2 V peak-to-peak per 1'000 rpm with a load resistance of $\geq 100 \text{ k}\Omega$

linearity better than $\pm 1.5 \%$. Phase shift smaller than 0.5° at 10'000 rpm.

Internal resistance : 0 - 10'000 rpm $\leq 1.3 \text{ k}\Omega$
10'000 - 20'000 rpm $\approx 1.3 - 2 \text{ k}\Omega$
40'000 rpm $\approx 3 \text{ k}\Omega$

2.2. Mounting

The pulse transducer can only be used with the flange MT-A/A.

In order to obtain a correct mounting of the transducer and the right gap between the head of the transducer and the pulse wheel, follow the instructions given below (see annex drawing VZ556/1a):

- Remove the screw cap on the MT-A/A. The teeth of the pulse wheel can be seen.
- The taller reference tooth of the pulse wheel can be seen through the opening. The reference tooth has a tiny hole on one side.
- Turn the flange by hand to obtain the right position.
- Unscrew the transducer locknut.
- Screw the transducer in until it just touches the tooth.
- Then unscrew one turn. The thread is of 0.5 mm pitch. A gap of 0.5 mm is thus obtained between the head of the transducer and the reference tooth.
- Tighten the transducer locknut again.
- Turn the flange by hand to make sure that the transducer does not touch the pulse wheel.

APPLICATION EXAMPLE

In the annex, an example of the numerous applications of the pulse transducer JP 1412 is given with the associated electronics of the PERMODULE System.

- | | | | |
|---|-----------------------------|---------------------------|-----------------------------|
| 1 | Feststehende Lotanschlüsse | Broches à souder - stator | Stationary solder terminals |
| 2 | Steckverbindung | Liaison enfichable | Plug connector |
| 3 | Quecksilberübertragerzellen | Cellules de transmission | Mercury transmission cells |
| 4 | Zentrierbohrung | Trou de centrage | Centre boring |
| 5 | Montagebock | Support de montage | Mounting support |

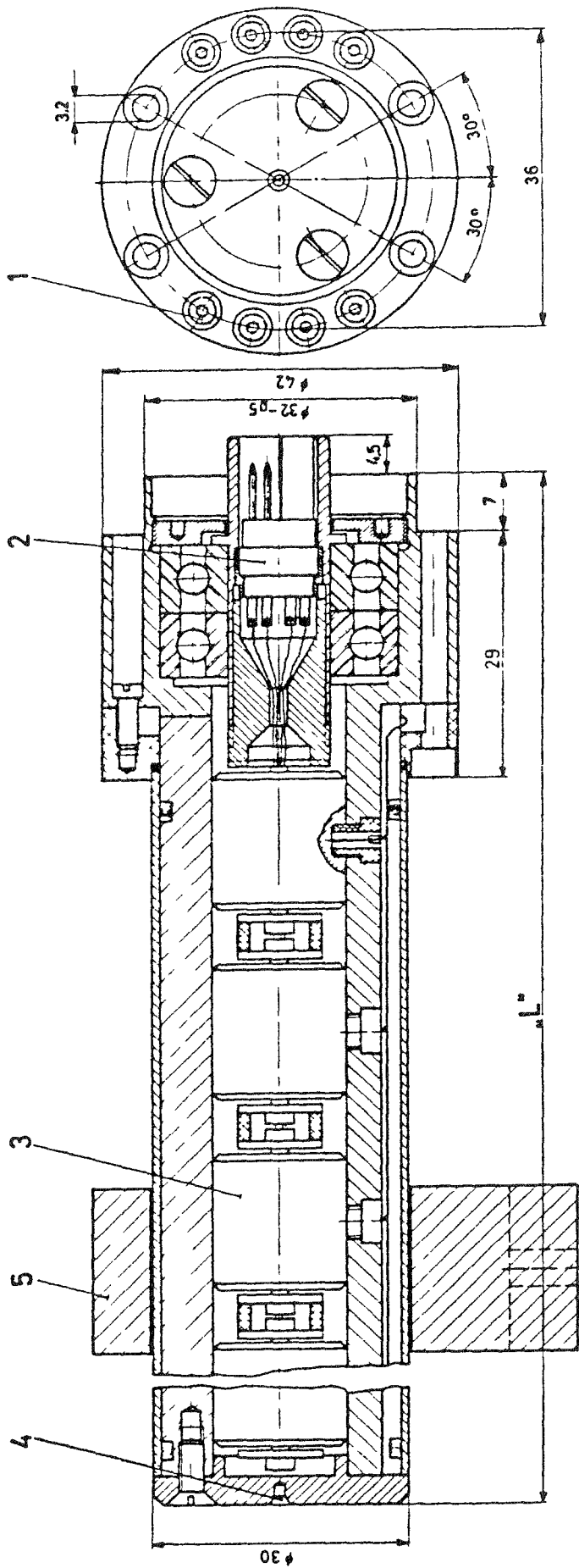

Verfasser:
 RB
 BB
 Löher
 Kontr.

Type	L
Part	222

Material		Mediennr.		Get	12 10 66	✓
Oberfläche		2:1		Gepr	13 10 66	Mh
Toleranzen	mm bis 50 mm			Gas		
Asid.	a	b	c	d	e	f
Brenn	g	h	i	j	k	l
Seitl.	m	n	o	p	q	r
	s	t	u	v	w	x
	y	z	aa	ab	ac	ad
Übertragerzell						
Partie de transmission						
Transmitting part						
			MT-	/A		VZ 558 C
vibro-meter ag FRIEDRICH SCHMIDT						

FK-15/B

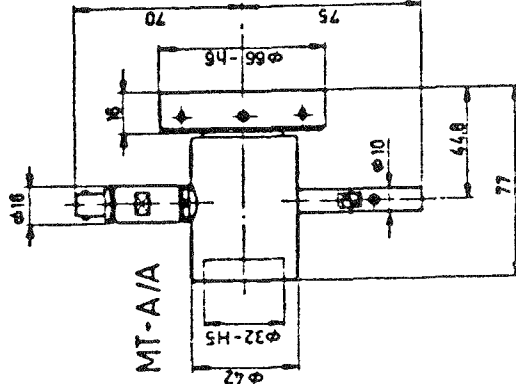
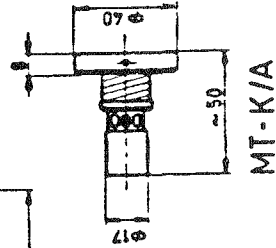
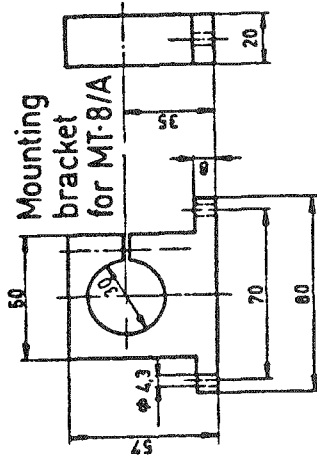
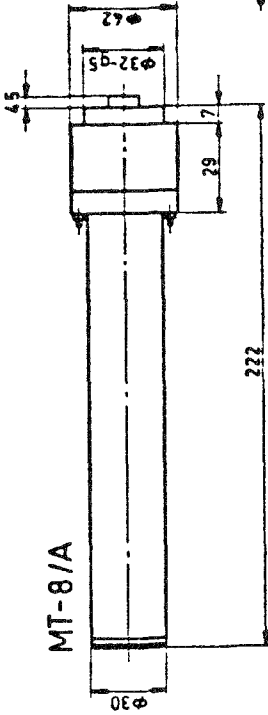
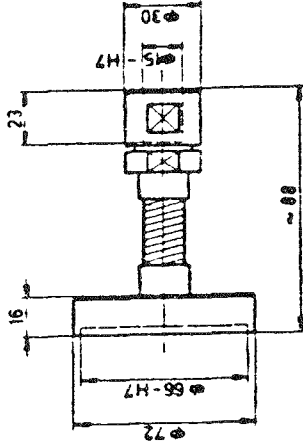

g	26.11.82	MT-8/A	1987	15.9.77	16.9.77
And	Datum	Vision	Get	Gepr	Gez
Ere durch	Ere für	Gepr	Gez	Gez	Gez

vibro-meter sa 1802003 0011218.LUB	
Code word	No 28713
VZ 940 a	

QUECKSILBERDREHBERTRAGER
mit KUPPLUNGEN

- 1 Feststehende Lötanschlüsse
- 2 Steckverbindung
- 3 Quecksilberübertragungszellen
- 4 Zentrierbohrung
- 5 Flexibler Antrieb
- 6 Montagebock
- 7 Rotierende Lötanschlüsse

- Broches à souder - stator
- Liaison enfichable
- Cellules de transmission
- Trou de centrage
- Transmission flexible
- Support de montage
- Bronches à souder-rotatives

- Stationary solder terminals
- Plug connector
- Mercury transmission cells
- Centre boring
- Flexible transmission
- Mounting support
- Rotating solder terminals

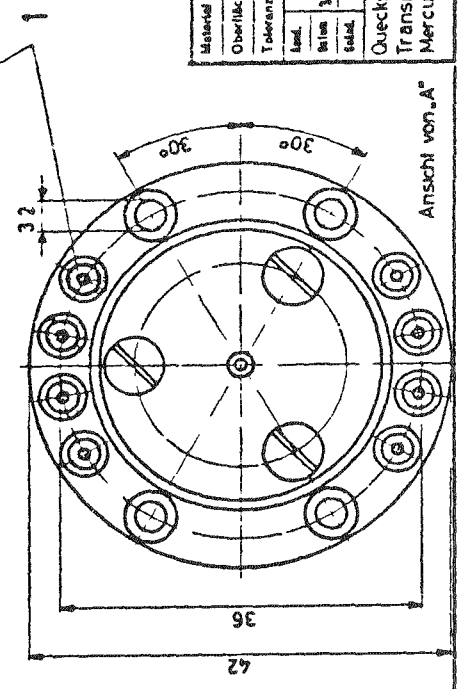
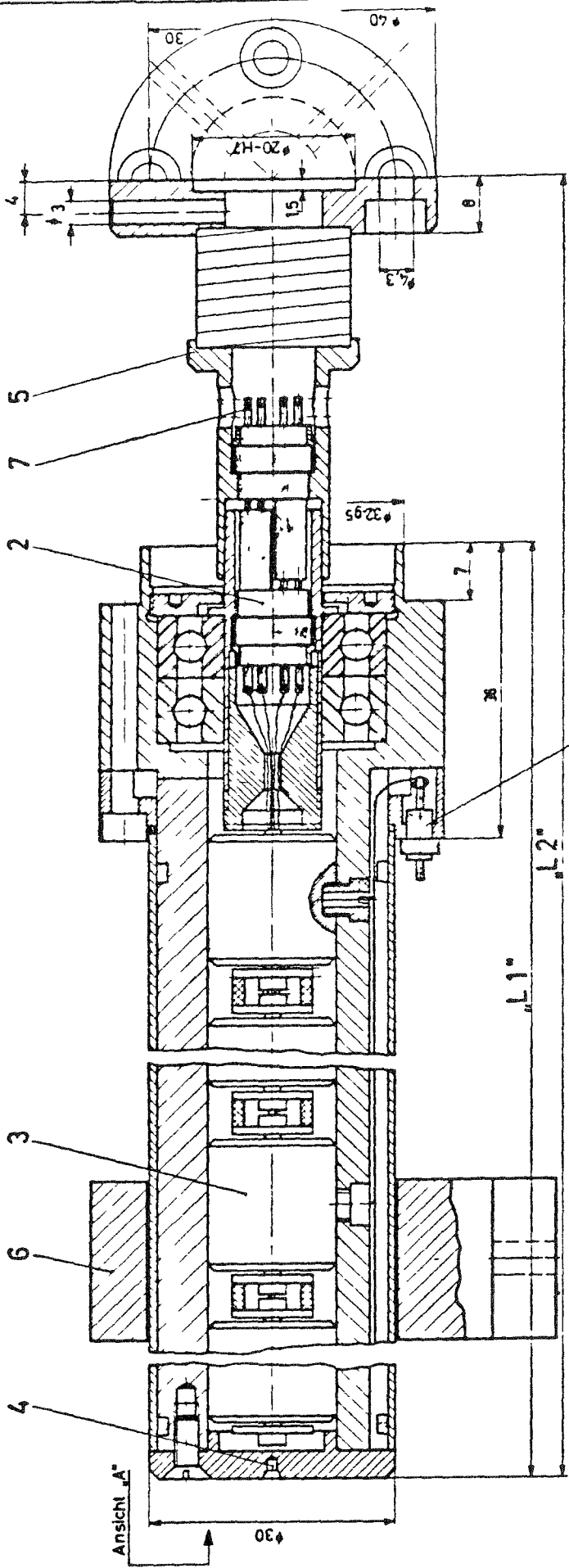

Material	Maßstab		Gas	12 18 24	1/4
Oberfläche	2:1		Gaspr	13 10 6 6	1/4
Toleranzen	mm bis 50 mm		Gas		
Best.	a	b	c	d	e
Strom	3.1 6 6.1	5 11 6 9	10 11 7.5		
Isolat.	1/2		1/2		1/2
Ersatz durch: Ersatz für					
Ersatz für					
Quicksilberdrehübertrager mit flexiblem Antrieb					
Transmetteur rotatif à mercure avec transmission flexible					
Mercury slip-ringless transmitter with flexible transmission					
					VZ 557 C
					WIBRO-METER AG
					RECHENUNG S. 206-2

Type	L1	L2
MT-8/A	222	265.5

Hersteller:
 BB
 Löhner
 Hanf

Frühling
 Perle
 Brax
 Wille

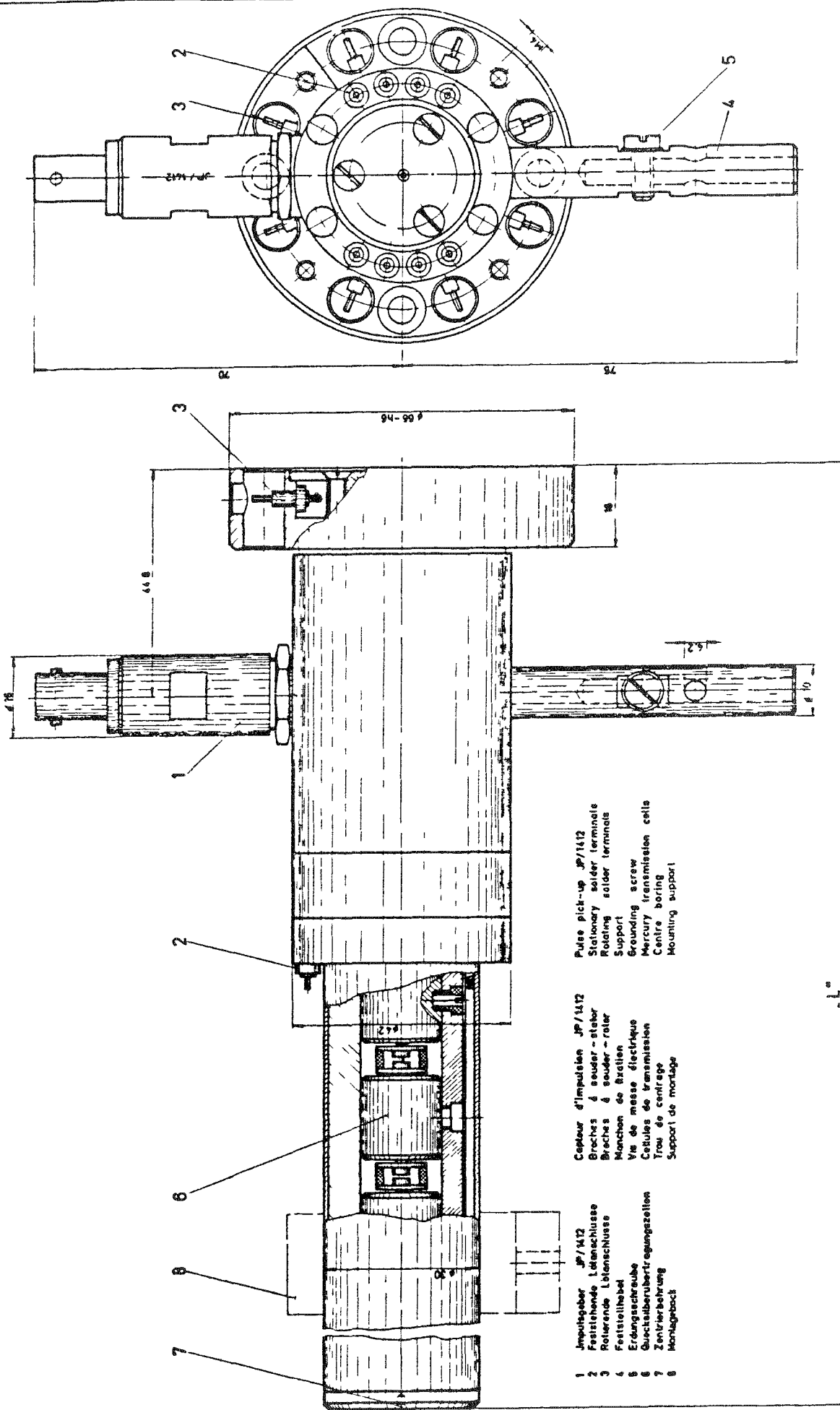

Pulse pick-up JP/1412
 Stationary solder terminal
 Rigid solder terminal
 Support
 Grounding screw
 Mercury transmission cells
 Centre boring
 Mounting support

Capteur d'impulsion JP/1412
 Broches à souder - stat
 Broches à souder - rig
 Manchon de fixation
 Vis de masse électrique
 Cellules de transmission
 Trou de centrage
 Support de montage

1 Impulsgeber JP/1412
 2 Feststehende Lötanschluss
 3 Rolierende Lötanschluss
 4 Feststellhebel
 5 Erdungsschraube
 6 Quecksilberübertragungsstellen
 7 Zentrierbohrung
 8 Montagebock

Charakteristika		Messwert		Einheit		Messwert		Einheit	
Ausgabe Nr. 145225		a 145225		b		c		d	
WILHELM BRÜCKE A.B.		FRIEDRICH SAUER		Ers. Nr.		Ers. Nr.		Ers. Nr.	
2		1		1		1		1	
Mercury slip-transmitter		mercury transmitter		VZ 556/1 Q		Mer. St.			

AUTYNE BESTEL	LEISTUNGSMITTEL	L
	MT-8/A	292
MT-A/A		

Modell:

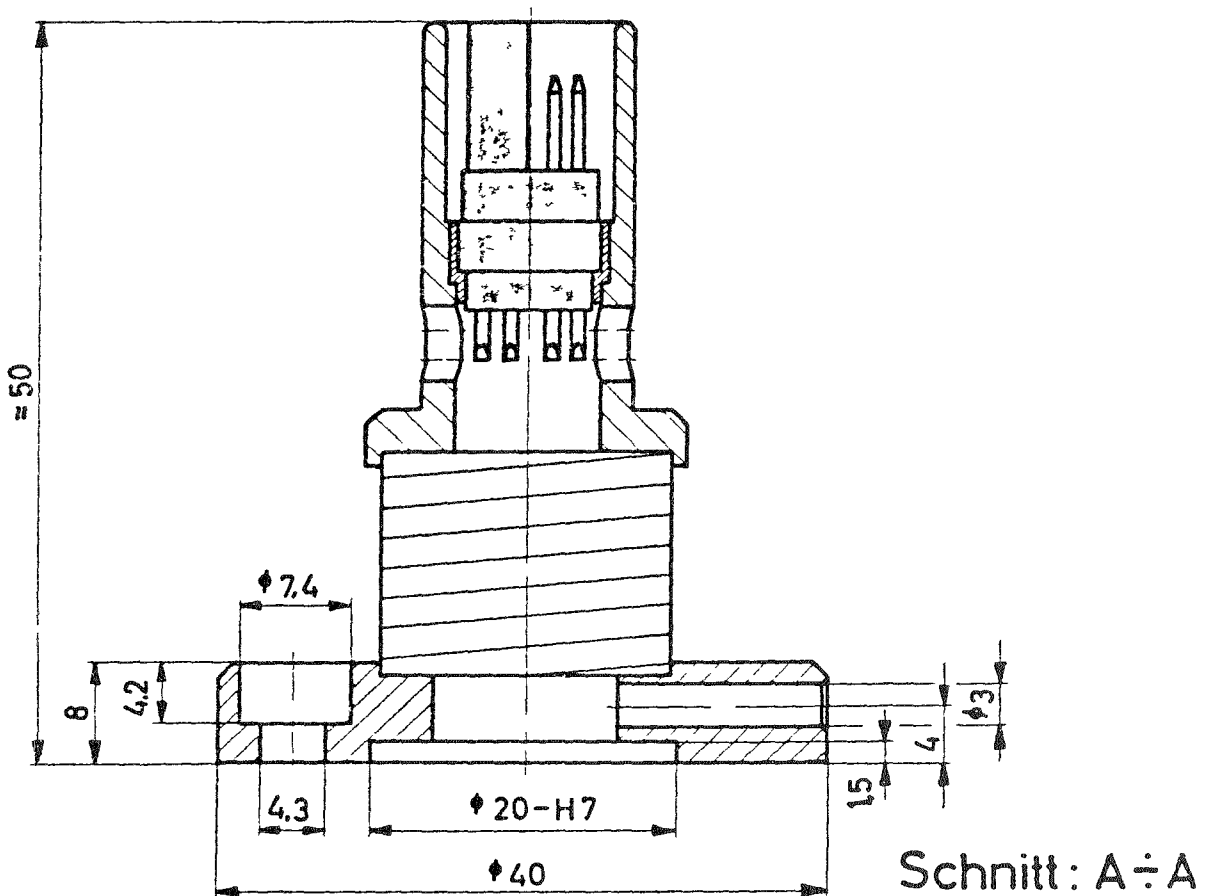
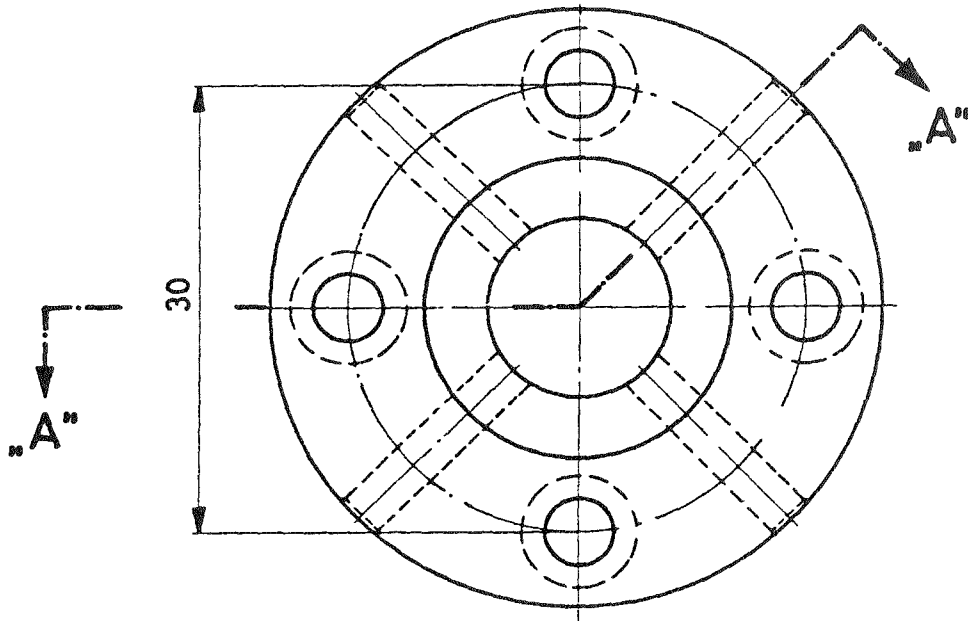

Schnitt: A ÷ A

Material :
 Oberfläche:
 Toleranzen: ± mm bis 50 mm ; ± mm über 50 mm

Maßstab
 2:1

Gez.	14.4.67	Z.
Gepr.		
Ges.		

Änd.	a	b	c	d	e	f	g
Datum							
Geänd.							

Ers. durch:
 Ersatz für:

vibro-meter ag
 FRIEBURG SCHWEIZ

Flexibler Antrieb
 Transmission flexible
 Flexible transmission

MT-... /A

VZ - 571

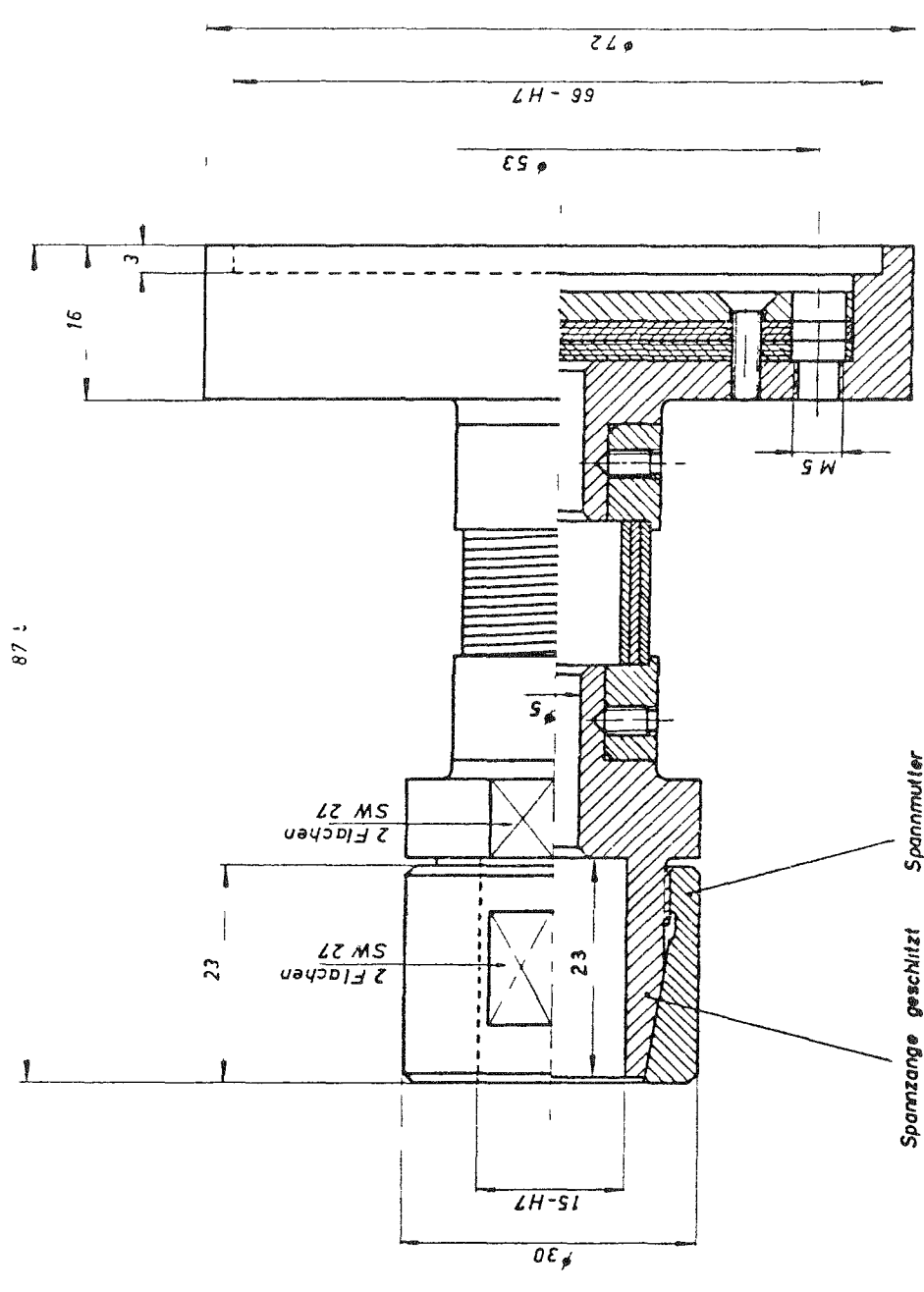

Spannzange geschlitz

Spannmutter

Material		Maßstab		Gez		26 6 67		vibro-meter ag	
Oberfläche		2 1		Gepr				FRIEDRICH SCHWEZ	
Toleranzen		mm bis 50 mm		mm über 50 mm		Ers durch		ZZ 420	
abd	a	b	c	d	e	f	g		
mitte									
Stahl									
Flexible Kupplung FK-15/B								VZ 579	

